

POTOCCO ITALY

indoor

POTOCO_{ITALY}



002

Since
1919

01.

003

Family is our starting point

Creatività italiana, tradizione artigianale e vocazione internazionale sono i tratti distintivi di Potocco, azienda a conduzione familiare, fondata nel 1919 da Domenico Potocco a Manzano (UD).

Italian creativity, artisan tradition and international vocation are the distinctive traits of Potocco, family-run company founded in 1919 by Domenico Potocco in Manzano (Udine).

Da piccola bottega artigiana per la produzione di sedie, Potocco si è evoluta nel corso degli anni trasformandosi in una vera e propria realtà industriale, specializzata nella creazione di arredi per la casa e il contract, adatti sia agli ambienti indoor che outdoor. Tappa fondamentale per l'azienda, la partecipazione nel 1961 al primo Salone del Mobile in qualità di socio fondatore.

Oggi guidata da Antonino Potocco, coadiuvato nel suo ruolo dalle figlie Alice e Marianna, quinta generazione della famiglia, l'azienda è presente in tutto il mondo grazie a una solida e vasta rete di distributori e all'apertura delle divisioni Potocco USA e Potocco Asia-Pacific.

From a small artisan workshop for the production of chairs, Potocco has evolved over the years, transforming into a large industrial reality, specialized in the creation of home and contract furnishing, for both indoor and outdoor environments. A milestone in the company's history is the participation at the first Salone del Mobile trade fair as a founding partner, in 1961.

Today the Company is run by Antonino Potocco, assisted in his role by his daughters Alice and Marianna, fifth generation of the family. The company is present throughout the world thanks to a solid and vast network of distributors and the opening of the Potocco USA and Potocco Asia-Pacific divisions.



Tailored industry is our soul

La cultura artigianale come patrimonio aziendale ha permesso a Potocco di coniugare negli anni i vantaggi di una moderna produzione in serie alla cura del dettaglio tipica delle lavorazioni manuali. Dopo un secolo di storia l'azienda realizza ancora internamente tutte le fasi produttive comprese le più delicate, dall'intreccio a mano, alla lavorazione del legno e dei diversi materiali.

Un connubio perfetto dove tradizione e innovazione si incontrano per garantire i più alti standard qualitativi.



The artisan tradition as a corporate asset has permitted Potocco to combine over the years the advantages of modern mass production with the attention to details typical of manual processing. After a century of history, the company still manages all production stages internally, including the most delicate ones, from hand weaving to the processing of wood and various other materials. A perfect union where tradition and innovation meet, guaranteeing the highest quality standards.

Bespoke
is our state of mind



Punto di forza di Potocco è da sempre la grande capacità di personalizzazione offerta al cliente: grazie a una produzione gestita internamente e all'abilità nella lavorazione dei materiali, l'azienda è in grado di realizzare su misura ogni proposta, customizzandola sulla base di specifiche richieste.

Potocco's strength has always been the great customization ability offered to the customer: thanks to its entirely managed in-house production and its ability to work different materials, the company is able to tailor each proposal, customizing it on the basis of specific requests.



L'expertise maturata in oltre un secolo d'attività si manifesta nell'estrema cura dei dettagli, tipica della tradizione artigianale, nella lavorazione dei diversi materiali ma anche negli intrecci realizzati a mano in canna e cordino che contribuiscono a creare proposte uniche dal gusto sempre nuovo e fresco.

The expertise gained in over a century of activity manifests in the careful attention to details, typical of artisan tradition, in the processing of various materials and in the handmade weavings made in cane and ropes, which contribute to the creation of unique proposals with a taste that is always new and fresh.

Uncompromising quality is our mission



Home and Contract are part of our job

POTOCO
ITALY

Home division

Contract division

Standard products

Personalized standard products

Custom made

Concepita prima di tutto per la casa, la proposta di Potocco si rivolge contemporaneamente anche al mondo contract. Il legame indissolubile e profondo dell'azienda con il mondo del progetto trova infatti ulteriore espressione in questo settore con progetti che spaziano a 360° dall'hospitality al corporate, dal retail al navale.

Tre possibilità di fornitura assicurano infatti un'offerta eclettica e versatile che si adatta in toto alle richieste del cliente. Prodotti da catalogo, custom made e progetti ad hoc rispondono con pari efficacia alle esigenze della committenza, supportata in tutte le fasi, dall'ideazione del progetto al servizio d'assistenza post vendita.

Designed above all for the home, Potocco's proposals are also aimed at the world of contract furnishing. The profound and indissoluble connection of the company with the world of project furnishing finds a further expression in this sector through projects that cover the full range of activities, from hospitality to corporate spaces, from retail to naval.

Three possibilities of supply guarantee a versatile and eclectic range that may be adapted completely to the customer's requirements. Catalogue's products, custom-made and ad hoc projects respond with equal effectiveness to the customer's needs, supported at every stage, from the project's conception to the after-sales assistance.



Selected references

Restaurant, cafés, lounge

AUSTRALIA

Nick's Bondi Beach (Sidney)
Port Phillip Estate Winery (Melbourne)
Star City Casino (Sidney)

AUSTRIA

Gipfel Restaurant Kitzsteinhorn (Kaprun)
Travel Charme Hotel (Hirschegg)
Restaurant Goldader (Tamsweg)
Sky Bar (Graz)

BERMUDA

Mediterraneo Bar (Hamilton)

FRANCE

Restaurant Le Passage (Lyon)
Downtown Restaurant (Disneyland Paris)

GERMANY

Beef Grill Club KDW (Berlin)
Restaurant Fellini (Stuttgart)
20° Restobar (Düsseldorf)
Moevenpick Marché Wilhelma (Stuttgart)

GREECE

Hotel Grande Bretagne (Athens)
Rodos Palace Hotel (Rhodes)

HOLLAND

Calaboose Rotterdam (Rotterdam)
Bernardus Golf Club (Cromvoirt)

ITALY

Armani Café (Milan)
Café Les Paillotes-De Cecco (Pescara)

JAPAN

Botanica Midtown (Tokyo)
Rappongi Hills Club (Tokyo)

PRINCIPALITY OF MONACO

Casinò (Monte Carlo)
Forum Grimaldi (Monte Carlo)
Ristorante Mada One (Monte Carlo)

PORTUGAL

Vale Dos Pinheiros (Almancil)

QATAR

Oryx Lounge (Doha)

RUSSIA

Tatler Club Moscow_Russia (Moscow)
Torro Grill - Mercure (Kaliningrad)
Mercur Crystal Palace (Kaliningrad)

SPAIN

Central Café (Barcelona)
Restaurante El Pescador (Madrid)

SWEDEN

Puntus By The Sea (Stockholm)

SWITZERLAND

Villa Schweizerhof (Lucerne)

UNITED ARAB EMIRATES

Al Jawaher (Sharjah)
The Seafood Restaurant, Aviation Club (Dubai)

UNITED KINGDOM

Bibendum Oyster Bar (London)
Conran's Restaurant (London)
Coq d'Argent (London)

USA

Aria De Cuba (New York)
Blue Water Grill (Chicago)
Planet Hollywood (New York)
Bogey Hills Country Club (Atlanta)

Hotel

AUSTRIA

Falkensteiner (Cristallo and Carinzia)
Hilton Hotel (Vienna)
Thermenhotel (Bad Ischl)
Hotel Andaz Vienna al Belvedere (Wien)
Alpin Resort Reiterhof (Saalbach)

AZERBAIJAN

Intourist Hotel Baku (Baku)

BELGIUM

Hotel Radisson Blu (Antwerp)
Renaissance Brussels Hotel (Bruxelles)

CANADA

The W Hotel (Montreal)

CHINA

Hotel Four Season (Shenzhen)

DENMARK

Scandinavia Hotel (Copenhagen)

FRANCE

La Coquillade Hotel (Garbas)
Hotel Mandarin Oriental (Paris)
Hotel Hilton (Evian)
Hotel Hyatt (Paris)
Hotel de Paris (Saint Tropez)
Hotel Sinner (Paris)

GERMANY

Dorint Hotel (Germany)
Ritz Carlton (Berlin)
Hotel Goliath (Regensburg)

GREECE

Ledra Marriott Hotel (Athens)

ESTONIA

Palace hotel (Tallin)

HUNGARY

Marriott (Budapest)

ITALY

Hotel Gallia (Milan)
Porto Piccolo Luxury Resort (Sistiana)
Hotel Du Lac et Bellevue (Bardolino)
Hotel Sportsman (Bardolino)
Hotel Schwarzenstein (Luttach)

MALDIVES

Cheval Blanc Resort (Randheli)

PRINCIPALITY OF MONACO

The Fairmont Montecarlo (Montecarlo)

QATAR

Al shamal Hotel Five Star Family Resort (Al Ruwais)

SAUDI ARABIA

Riyadh Hotel (Riyadh)
Emirates Park tower hotel (Dubai)

SINGAPORE

Hotel Pan Pacif (Singapore)

SLOVENIA

Intercontinental Lubiana (Lubiana)

SPAIN

Kempinski Hotel Baia (Marbella)

SOUTH KOREA

Hotel Conrad (Seoul)
The W Hotel (Seoul)

SWITZERLAND

Hotel Storchen (Zurich)
Hotel Elnzerhorn Spa & Wellness (Lenzerheide)
Hotel Grindelwald (Suhr)

THAILAND

Four Season (Bangkok)

UKRAINE

Holiday Inn (Kiev)

UNITED ARAB EMIRATES

Hotel New Archaic (Dubai)
Kingdom Hotel Investment (Dubai)

UNITED KINGDOM

Shangri-La Hotel At The Shard (London)
Hilton Hotel (Leeds)
Hyatt Regency Hotel (Birmingham)
Plaza Hotel Hyde Park (London)

USA

Ritz Carlton (Chicago)
Sheraton Fisherman's Wharf (San Leandro)
Isla Bella Beach Resort (Marathon)
Intercontinental SF Hotel (San Francisco)
Renaissance DC Lobby Hotel (Washington DC)
Hard Rock Hotel (Atlantic City)
Embassy Suites by Hilton San Juan Hotel Puerto Rico (Puerto Rico)
San Mateo Marriott (San Mateo)
Restaurant Atelier Des Hoteles (Mexico)
Disney Animal Kingdom Lodge Walt Disney (Orlando)

Naval

MSC

MSC Meraviglia
MSC Seaside
MSC Seaview
MSC Bellissima
MSC Grandiosa

NORWEGIAN CRUISE LINE

Norwegian Joy
Norwegian Bliss
Norwegian Encore

TUI CRUISES

Mein Schiff 1, 6

COMPAGNIE DU PONANT

M/V Austral
M/V Le Ponant

GENTING HONG KONG

Crystal Debussy
Crystal Ravel

ROYAL CARIBBEAN CRUISE LINES

Anthem Of The Seas
Ovation Of The Seas
Quantum Class
Quantum Of The Seas
Voyager Of The Seas
Independence Of The Seas
Mariner Of The Seas
Spectrum Of The Seas

VIKING RIVER CRUISES

COSTA CROCIERE

Aida Diva
Aida Luna
Aida Bella
Aida Vita
Aida Aura
Aida Blu
Aida Stella
Aida Sol
Aida Mar

LEVANTE FERRIES

Ferryboat: Fior di Levante

ATTICA FERRIES

Ferryboat: Superfast XI, XII
Ferryboat: Blue Star Paros
Ferryboat: Blue Star Naxos
Ferryboat: Blue Star Ithaki

Corporate

AUSTRALIA

Victoria Racing Club (Melbourne)
Department of Education (Paramatta)

AUSTRIA

Volksbank (Salzburg)
Martini Beleuchtungen (Vienna)

CHINA

CNC (Hangzhou)

FRANCE

Foncier Construction
Inédit Joaillier (Paris)

GERMANY

Golf Club Bad Nauheim (Seeaux)
Mannesmann AG (Konigswinter)

ITALY

Virgin Fitness Center

JAPAN

Tokyo Airport (Tokyo)
Tokyo University (Tokyo)

PRINCIPALITY OF MONACO

Red Bull Energy Drink
CFM Indosuez Private Banking (Montecarlo)

SWEDEN

World Of Golf (Gothenburg)

SWITZERLAND

Credit Suisse (Zurich)
Banque Pictet (Geneva)
Kurhotel & Privatklinik Oberwaid (St. Gallen)
Bad Ragaz Golfclub (Bad Ragaz)
Zurich assicurazioni (Zurich)
Kusnacht Klinik (Kusnacht)
Widenmoos Resort (Reitnau)

UNITED ARAB EMIRATES

Pavillion at the park (Dubai)

UNITED KINGDOM

Morgan Stanley (London)
Swiss Re Life & Health (London)
Estée Lauder (London)
Rolls Royce (London)
Barclays Bank (London)
Royal National Lifeboat Inc. (Poole)
United Designer (Pearl)

USA

Smithsonian Institute (Washington)
Swiss Embassy (Washington)

POTOCO_{ITALY}

In- dex

01.

SINCE 1919

Family is our starting point \ 004
Tailored industry is our soul \ 006
Bespoke is our state of mind \ 008
Uncompromising quality is our mission \ 010
Home and Contract are part of our job \ 012

02.

ABACO

Catalogue overview \ 021

03.

PRODUCT COLLECTIONS

Anfora \ 232
Arial \ 244
Aura \ 110
Avant \ 218
Blossom \ 130
Bon Bon \ 056
Bon Ton \ 300
Candy \ 228
Concha \ 198
Coulisse \ 106
Cut \ 260
Dance \ 196
Diva \ 302
Elodie \ 274
Grace \ 094
Greta \ 296
Herm \ 180
Hishi \ 184
Jolly \ 324
Keel \ 068
Lars \ 084
Léna \ 124
Linus \ 264
Little T \ 336
Loom \ 156
Lyz \ 146
Memory \ 208
Miura \ 314

Opus \ 072
Otab \ 088
Otta \ 332
Pipe \ 212
Plissé \ 202
Pocket \ 120
Purple \ 188
Rondò \ 194
Ropu \ 176
Scheggia \ 116
Sen \ 284
Slice \ 328
Spring \ 290
Stay \ 142
Stilla \ 310
Tale \ 252
Terrazzo \ 080
Torso \ 170
Track \ 240
Tray \ 256
Velis \ 036
Venus \ 320
Vigo \ 206
Wood_Y \ 278
Yoisho \ 270

04.

TECHNICAL SHEET

Drawings \ 341

05.

FINISHES

Materials & Coverings \ 373

Aba-
co

02.

Sedie & Poltroncine | Chairs & Small armchairs



Blossom
840
collection 130
technical sheet 345



Blossom
840/P
collection 130
technical sheet 345



Candy
943
collection 228
technical sheet 347



Candy
943/P
collection 228
technical sheet 347



Concha
905
collection 198
technical sheet 347
others 220-221\246



Lyz
918/I
collection 146
technical sheet 356



Lyz
918/PI
collection 146
technical sheet 356



Lyz
918/G
collection 146
technical sheet 356



Lyz
918/PG
collection 146
technical sheet 356



Lyz
918/GI
collection 146
technical sheet 356



Concha
905/P
collection 198
technical sheet 347
others 220-221\246



Coulisse
941/P
collection 106
technical sheet 347
others 111



Grace
834
collection 094
technical sheet 350



Grace
834/P
collection 094
technical sheet 350



Grace
834/PMC
collection 094
technical sheet 350
others 114-115



Lyz
918/PGI
collection 146
technical sheet 356



Lyz
918/GC
collection 146
technical sheet 356



Lyz
918/PGC
collection 146
technical sheet 356



Lyz
918/GCI
collection 146
technical sheet 356



Lyz
918/PGCI
collection 146
technical sheet 356



Greta
695 - 695/SF
collection 296
technical sheet 351



Greta
695/P - 695/PSF
collection 296
technical sheet 351



Keel
922
collection 068
technical sheet 352



Keel
922/P
collection 068
technical sheet 352



Lars
902
collection 084
technical sheet 353
others 216-217



Lyz
918/SL
collection 146
technical sheet 356



Lyz
918/PSL
collection 146
technical sheet 356



Lyz
918/SLI
collection 146
technical sheet 356



Lyz
918/PSLI
collection 146
technical sheet 356



Lyz
918/U
collection 146
technical sheet 356



Lars
902/P
collection 084
technical sheet 353



Léna
903
collection 124
technical sheet 353
others 074



Léna
903/P
collection 124
technical sheet 353
others 074



Lyz
918
collection 146
technical sheet 356



Lyz
918/P
collection 146
technical sheet 356



Lyz
918/PU
collection 146
technical sheet 356



Lyz
918/UI
collection 146
technical sheet 356



Lyz
918/PUI
collection 146
technical sheet 356



Memory
842/P
collection 208
technical sheet 357
others 214



Miura
776/W
collection 314
technical sheet 357



Miura
776/PW
collection 314
technical sheet 357



Miura
776/P - 776/PII
collection 314
technical sheet 357



Otta
940
collection 332
technical sheet 359



Slice
772
collection 328
technical sheet 363



Slice
772/PW
collection 328
technical sheet 363



Jolly
751/AI-GAS
collection 324
technical sheet 352



Jolly
751/AII-GAS
collection 324
technical sheet 352



Linus
730/AI
collection 264
technical sheet 354



Miura
776/AW
collection 314
technical sheet 357



Plissé
929/A-GAS
collection 202
technical sheet 360



Slice
772/PI
collection 328
technical sheet 363



Velis
942
collection 036
technical sheet 368
others 279\285\306-307



Velis
942/7
collection 036
technical sheet 368



Velis
942/PB
collection 036
technical sheet 368
others 078-079\251



Velis
942/PB-7
collection 036
technical sheet 368



Plissé
929/S-GAS
collection 202
technical sheet 360



Torso
837/AI-GAS
collection 170
technical sheet 366



Velis
942/AS
collection 036
technical sheet 368



Velis
942/A
collection 036
technical sheet 368



Velis
942/AC
collection 036
technical sheet 368

024

025



Velis
942/PA
collection 036
technical sheet 368
others 060-061
090-091\235



Velis
942/PAG
collection 036
technical sheet 368



Velis
942/PAR
collection 036
technical sheet 368



Venus
757/P
collection 320
technical sheet 370



Velis
942/A2
collection 036
technical sheet 368



Velis
942/APA-GAS
collection 036
technical sheet 368

Sgabelli | *Stools*



Blossom
840/A
collection 130
technical sheet 345



Blossom
840/A-GAS
collection 130
technical sheet 345



Blossom
840/AP-GAS
collection 130
technical sheet 345



Bon Ton
770/A-GAS
collection 300
technical sheet 346



Jolly
751/AIIW
collection 324
technical sheet 352

Poltrone | *Armchairs*



Blossom
910/PL
collection 130
technical sheet 345



Cut
910/PLG
collection 260
technical sheet 348



Cut
840/PL
collection 260
technical sheet 348



Grace
834/PB
collection 094
technical sheet 350

Pouf & Panche | Poufs & Benches



Léna
903/PL
collection 124
technical sheet 353



Léna
903/PLG
collection 124
technical sheet 353
others 123\185



Loom
880/PC
collection 156
technical sheet 355
others 280



Otta
940/L
collection 332
technical sheet 359



Cut
910/PP
collection 260
technical sheet 348



Cut
910/PLG
collection 260
technical sheet 348



Dance
792/O
collection 196
technical sheet 348



Herm
925/O80
collection 180
technical sheet 351



Purple
935/P
collection 188
technical sheet 361



Scheggia
906/PLR
collection 116
technical sheet 362



Scheggia
906/PLI
collection 116
technical sheet 362



Spring
841/P
collection 290
technical sheet 364



Herm
925/O60
collection 180
technical sheet 351



Herm
925/O45
collection 180
technical sheet 351
others 161



Otta
940/O
collection 332
technical sheet 359



Ropu
888/CQR-IN
collection 176
technical sheet 362
others 224-225\276-277



Stay
909/PL
collection 142
technical sheet 364
others 187\253



Track
919/L
collection 240
technical sheet 367



Velis
942/PLA
collection 036
technical sheet 368



Velis
942/PLAG
collection 036
technical sheet 368



Spring
841/S
collection 290
technical sheet 364



Velis
942/O1
collection 036
technical sheet 368



Velis
942/O2
collection 036
technical sheet 368



Velis
942/O3
collection 036
technical sheet 368



Velis
942/PLB
collection 036
technical sheet 368
others 257



Venus
757/PB
collection 320
technical sheet 370



Vigo
881/L
collection 206
technical sheet 370
others 164-165\179
289\311\337



Yoisho
904/PL
collection 270
technical sheet 371



Velis
942/O4
collection 036
technical sheet 368



Venus
757/O
collection 320
technical sheet 370

Divani | Sofas



Blossom
840/D
collection 130
technical sheet 345



Elodie
908/D
collection 274
technical sheet 349
others 224-225



Velis
942/DB
collection 036
technical sheet 368



Grace
834/D
collection 094
technical sheet 350



Loom
880/DC — 880/DC-200
collection 156
technical sheet 355
others 339



Loom
880/DB
collection 156
technical sheet 355



Loom
880/DCL+880/DCM
collection 156
technical sheet 355
others 313



Purple
935/D
collection 188
technical sheet 361



Spring
841/D
collection 290
technical sheet 364



Velis
942/DA
collection 036
technical sheet 368

Daybed | Daybeds

Tavoli | Tables



Anfora
879/T
collection 232
technical sheet 342
others 037



Aura
830/TC1
collection 110
technical sheet 343
others 299



Aura
830/TO1
collection 110
technical sheet 343



Blossom
840/TR1
collection 130
technical sheet 345
others 329



Bon Bon
770/TC
collection 056
technical sheet 346
others 201



Bon Bon
770/TO
collection 056
technical sheet 346



Bon Bon
770/TG-O
collection 056
technical sheet 346



Bon Bon
770/TG-R
collection 056
technical sheet 346



Diva
775/TC1
collection 302
technical sheet 349
others 210-211



Torso
837/T4
collection 170
technical sheet 366



Torso
837/TR
collection 170
technical sheet 366

Tavolini | *Coffee tables*



Diva
775/TO2
collection 302
technical sheet 349
others 109



Grace
834/TC1
collection 094
technical sheet 350



Grace
834/TO1
collection 094
technical sheet 350
others 319



Bon Bon
770/TB
collection 056
technical sheet 346
others 048\050-051



Hishi
871/TBC
collection 184
technical sheet 351
others 145\241



Hishi
871/TBQ
collection 184
technical sheet 351
others 145



Little T
878/TQ-50
collection 336
technical sheet 354
others 159

030

031



Linus
730/TC1
collection 264
technical sheet 354



Opus
893/TQ
collection 072
technical sheet 358
others 043\069\147



Opus
893/TR
collection 072
technical sheet 358
others 151\251



Little T
878/TQ-100
collection 336
technical sheet 354
others 047\158\159\161



Little T
878/TR
collection 336
technical sheet 354
others 164-165\280



Otta
940/T
collection 332
technical sheet 359



Pocket
894/TB
collection 120
technical sheet 360
others 143\243



Otab
883/T
collection 088
technical sheet 359
others 044\085\125
149\220-221\246\285



Pipe
885/TC
collection 212
technical sheet 360



Pipe
885/TR
collection 212
technical sheet 360



Rondò
827/TB
collection 194
technical sheet 362



Rondò
827/TM
collection 194
technical sheet 362



Ropu
888/TBC
collection 176
technical sheet 362
others 168-169\
224-225\276-277\313



Ropu
888/TBR
collection 176
technical sheet 362
others 117\168-169
276-277\288-289\311\313

Mobili contenitori | *Storage furniture*



Spring
841/TBC
collection 290
technical sheet 364



Spring
841/TBQ
collection 290
technical sheet 364



Spring
841/TBR
collection 290
technical sheet 364



Tray
872/TC
collection 256
technical sheet 367
others 168-169
192-193\207\263\291



Arial
870/ML
collection 244
technical sheet 342



Arial
870/MS
collection 244
technical sheet 342
others 145\253\263



Avant
884/MA
collection 218
technical sheet 344
others 090-091



Tray
872/TQ
collection 256
technical sheet 367
others 129\168-169
192-193\263\291



Tray
872/TR
collection 256
technical sheet 367
others 129\168-169
192-193\207



Avant
884/MB1
collection 218
technical sheet 344
others 214



Avant
884/MB2
collection 218
technical sheet 344
others 151\201\224-225



Avant
884/MB1-180 - 884/MB2-180
collection 218
technical sheet 344
others 263

032

Scrittoi & Consolle | *Writing desks & Consoles*



Arial
870/CS
collection 244
technical sheet 342
others 078-079\147



Linus
730/SCR
collection 264
technical sheet 354



Terrazzo
898/SCR
collection 080
technical sheet 366



Diva
775/M
collection 302
technical sheet 349



Sen
886/MA
collection 284
technical sheet 363
others 044\273



Sen
886/MB
collection 284
technical sheet 363
others 143\288-289\216-217\261

033



Wood_Y
889/SCR
collection 278
technical sheet 371



Wood_Y
889/CS
collection 278
technical sheet 371



Wood_Y
889/CSF
collection 278
technical sheet 371
others 050-051\311

Specchi | *Mirrors*



Stilla
890/S
collection 310
technical sheet 365
others 201\224-225
261\289



Tale
891/S
collection 252
technical sheet 365
others 078-079\187
243\249



Product
Collections

03.

DESIGN
MARIO FERRARINI

sedie | chairs
poltroncine | small armchairs
poltroncina pozzetto girevole | swivel tub chair
poltroncina pozzetto schienale intrecciato | woven backrest tub chair
poltrone | armchairs
poltrona girevole | swivel armchair
divani | sofas
sgabelli | stools
sgabello up&down | up&down stool
panche | benches

Velis

Velis è un'ampia collezione di sedute pensata per rispondere alle diverse esigenze del vivere quotidiano. Declinata nelle versioni sedia e poltroncina, poltrona, con schienale in differenti altezze, poltroncina pozzetto, poltroncina pozzetto con schienale intrecciato a mano, poltrona girevole, divanetto a due posti, sgabello singolo o doppio, sgabello up&down e panca. Velis esplora e risolve al meglio la relazione tra l'imbottito e la struttura: gambe e seduta si incontrano in una cornice, in frassino o noce Canaletto che, lasciata a vista, conferisce ricchezza al progetto. La poltroncina pozzetto è stata pensata anche per un utilizzo outdoor ed è disponibile con schienale intrecciato a mano.

Velis is a wide collection of seating thought to satisfy different demands. Declined in the chair, small armchair, armchair versions, with backrest in different heights, tub chairs, tub chair with hand-woven backrest, swivel armchair, two-seater sofa, single or double stool, up&down stool, and bench. Velis explores and solves the relationship between padding and structure: legs and seat meet in a frame, in ash wood or Canaletto walnut that, left in sight, gives richness to the project. The tub chair is also available for an outdoor use with hand-woven backrest.



VELIS poltroncina pozzetto | tub chair - ANFORA tavolo | table







VELIS

942/7
sedia schienale alto | high backrest chair

942/PB7
poltroncina schienale alto | high backrest small armchair



VELIS sedia | chair, poltroncina | small armchair - OPUS tavolo | table



VELIS poltroncina pozzetto girevole | swivel tub chair - OTAB tavolo | table - SEN credenza | cabinet



VELIS / 942/PAG
 poltroncina pozzetto girevole | swivel tub chair



VELIS | 942/DA | 942/PLA
divano | sofa | poltrona | armchair



VELIS poltrona | armchair, divano | sofa, panca | bench - LITTLE T tavolino | coffee table



VELIS poltrona | armchair, divano | sofa - BON BON tavolino | coffee table

VELIS / 942/PLB
poltrona | armchair

942/DB
divano | sofa





050

VELIS

942/PLAG
poltrona girevole | swivel armchair



051

VELIS poltrona girevole | swivel armchair - BON BON tavolino | coffee table - WOOD_Y consolle | console

VELIS 942/O3 panca | bench 942/O1 panca | bench



052

VELIS 942/O4 panca | bench 942/O2 panca | bench



VELIS panche | benches



VELIS sgabello | stool



VELIS 942/A
sgabello alto | barstool



VELIS 942/AS
sgabello basso | counterstool



VELIS 942/A2
sgabello doppio | double stool

942/AC
sgabello | stool

VELIS 942/APA-GAS
sgabello up&down | up&down stool



DESIGN
ALEXANDER LORENZ

tavoli | tables
tavolino | coffee table

Bon Bon

Il disegno a fasce intrecciate della base in metallo è l'elemento che caratterizza la famiglia di tavoli e tavolini Bon Bon. Una sofisticata combinazione di materiali, dimensioni e colori, permette di personalizzare il tavolo in base alle specifiche esigenze.

A scelta, l'essenziale piano è proposto in vetro trasparente temperato, in noce Canaletto o in una preziosa gamma di marmi. All'insegna della versatilità, la base del tavolo può essere modulata a seconda delle dimensioni del piano disponibile nelle versioni circolare, ovale e rettangolare.

The design with intertwined bands of the metal base is the element that characterizes the Bon Bon tables and coffee tables' family. A sophisticated combination of materials, sizes and colors allows you to customize the table according to specific needs.

The essential top is available in transparent tempered glass, in Canaletto walnut or in a precious range of marbles. In the name of versatility, the table's base can be modulated according to the size of the top available in circular, oval, and rectangular versions.





BON BON

770/TO
tavolo | table



BON BON

770/TC
tavolo | table



BON BON / 770/TG-O
tavolo | table



BON BON / 770/TG-R
tavolo | table







BON BON | 770/TB
 tavolino | coffee table



BON BON tavolino | coffee table

DESIGN
M+V

sedia | chair
poltroncina | small armchair

Keel

La sedia e poltroncina Keel nascono da una ricerca sul tema del rapporto tra rigore geometrico e sinuosità organica. Keel, nome che richiama il mondo della nautica, rappresenta infatti il tentativo di trovare il miglior equilibrio tra una struttura lineare in tondino di metallo ed elementi d'appoggio in massello di frassino dalle forme morbide e sinuose che presentano una lavorazione molto particolare. Keel è disponibile anche nella versione outdoor in massello di iroko.

Keel chair and small armchair were born from the research between geometric rigor and organic sinuosity. Keel, name recalling the nautical world, represents the attempt to find equilibrium between the linear structure in embossed metal rod and the sinuous and soft lines of the backing elements in solid ash wood, presenting a very particular processing. Keel is available also in the outdoor version in solid Iroko wood.



KEEL sedia | chair, poltroncina | small armchair - OPUS tavolo | table



KEEL / 922/P
poltroncina | small armchair



KEEL / 922
sedia | chair

DESIGN
BERNHARDT & VELLA

tavoli con base componibile | tables with modular base

Opus

Il tavolo Opus è caratterizzato da un particolare disegno della base, costituita da un elemento singolo che viene ripetuto e posizionato a seconda della misura del piano. La base è disponibile in massello di frassino o noce Canaletto, e il piano, che può essere scelto tra le varianti quadrato, circolare e a botte, è disponibile in una preziosa gamma di marmi, frassino e noce Canaletto. Dal disegno geometrico e lineare, Opus è il protagonista di una discreta zona dining così come di un'importante sala da pranzo.

The Opus table is characterized by a particular design of the base, consisting of a single element that is repeated and positioned according to the size of the top. The base is available in solid ash wood or Canaletto walnut, and the top, which can be chosen among the square, circular and barrel variants, is available in a precious range of marbles, ash wood and Canaletto walnut. With a geometric and linear design, Opus is the protagonist of a discreet dining area as well as of an important dining room.



OPUS

893/TQ

tavolo con base componibile | table with modular base



OPUS tavolo con base componibile | table with modular base - LÉNA sedia | chair, poltroncina | small armchair



OPUS

893/TR

tavolo con base componibile | table with modular base





OPUS tavolo con base componibile | table with modular base - VELIS poltroncina | small armchair - ARIAL consolle | console - TALE specchio | mirror

DESIGN
NICOLA BONRIPOSI

scrittoio | writing desk

Terrazzo

Lo scrittoio terrazzo è ideale sia per un angolo studio che di lavoro, sia per una casa che per la camera di un hotel. L'ispirazione per questo progetto nasce nei viaggi del designer, Nicola Bonriposi. Il suo profilo, che rimanda alle tipiche risaie a terrazza indonesiane, crea una spalla oversize che ne amplia la funzionalità.

The writing desk Terrazzo is ideal for both a study and a work corner, for a home and for a hotel room. The project's inspiration comes from the designer's travels, Nicola Bonriposi. Its profile, recalling the typical Indonesian terraces' rice fields, creates an oversized shoulder that expands its functionality.



TERRAZZO

898/SCR
scrittoio | writing desk

082

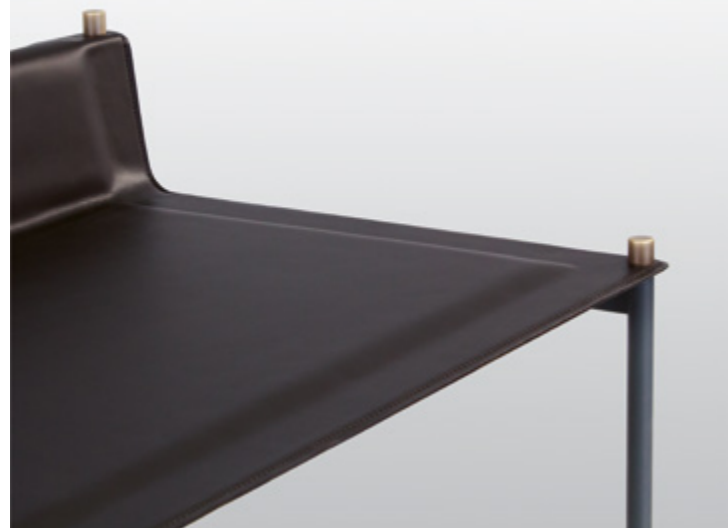

DESIGN
GABRIELE E OSCAR BURATTI

sedia | chair
poltroncina | small armchair

Lars

La sedia e poltroncina imbottite Lars si contraddistinguono per il particolare disegno delle gambe che senza soluzione di continuità sembrano scaturire dalla seduta e dallo schienale.

Completamente rivestita in tessuto o pelle, Lars propone l'esito di una riflessione sul tema della seduta mono materica caratterizzata da una confezione sartoriale che veste perfettamente la struttura, interamente stampata in poliuretano espanso ignifugo, che cela al suo interno un'anima in metallo.

The Lars upholstered chair and small armchair stand out for the sinuous and special design of their legs, which appear to start from the seat and the backrest in one piece.

Fully covered in fabric or leather, Lars represents an interpretation of the single-material seating item, characterized by a tailored upholstery, which perfectly fits the entirely fire retardant polyurethane molded structure, hiding a metal core inside.



LARS sedia | chair, poltroncina | small armchair - OTAB tavolo | table - AVANT madia | sideboard



LARS / 902
sedia | chair

LARS / 902/P
poltroncina | small armchair



DESIGN
GABRIELE E OSCAR BURATTI

tavolo | table

Otab

Otab è una proposta giocata sulle proporzioni: al volume imponente della base fa da contrappunto l'essenzialità del piano. Un monolite materico che nasce dall'accostamento di due forme pure e geometriche, il cerchio e il cilindro. Un particolare dettaglio in ottone brunito solleva la base da terra e ne disegna il profilo.

Otab is a proposal played on proportions: the imposing volume of the base is counterpointed by the essentiality of the top. A material monolith that arises from the combination of two pure and geometric shapes, the circle, and the cylinder. A particular detail in bronzed brass lifts the base from the ground and draws its profile.



OTAB

883/T
tavolo | table



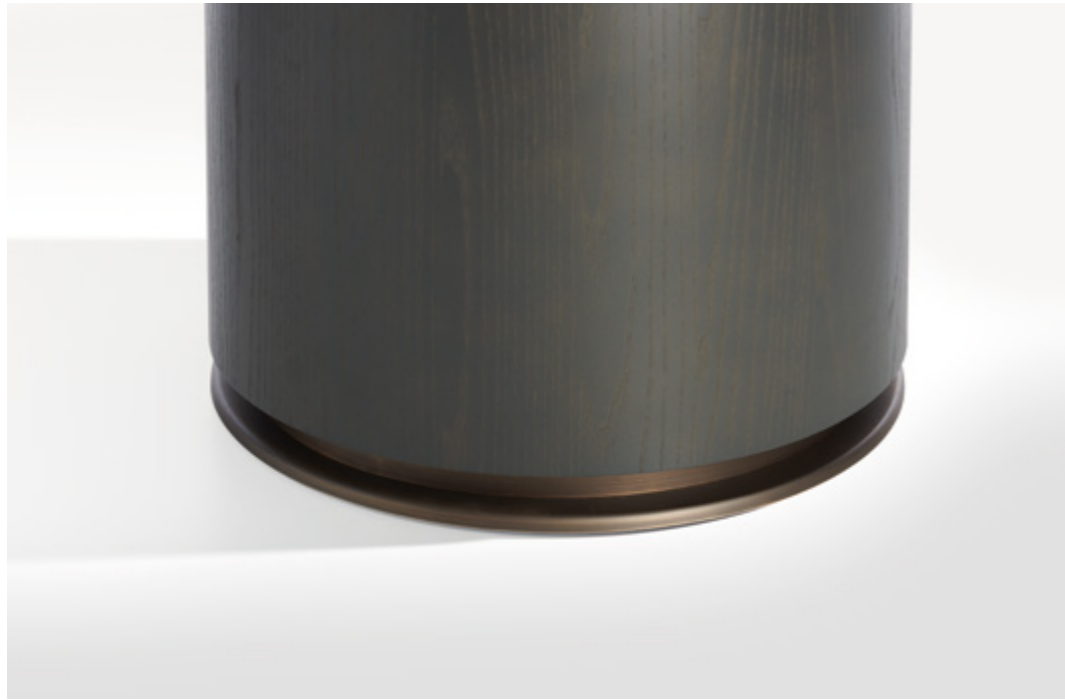

092



093

OTAB / 883/T
tavolo | table

DESIGN
MAURO LIPPARINI

sedia | chair
poltroncina | small armchair
poltroncina pozzetto | tub chair
poltrona | armchair
divano | sofa
tavoli allungabili | extendable tables

Grace

Trait d'union della collezione Grace è la struttura in massello di frassino spazzolato, modellata in forme geometriche, morbide ed avvolgenti declinate in sedia, poltroncina, poltroncina pozzetto, poltrona, divano e tavoli allungabili. Elemento di grande preziosità l'intreccio in canna, disponibile per sedute e divano, che crea una fitta trama donando un tocco di freschezza ed unicità ad ogni interno domestico.

The trait d'union of the Grace collection is the brushed solid ash wood frame, modelled in geometric and soft enveloping shapes, consisting of chair, small armchair, tub chair, armchair, sofa, and extendable tables. An element of great value is the woven cane insert, available for seats and sofa, which creates a dense texture giving a touch of freshness and uniqueness to any domestic interior.



GRACE poltroncina pozzetto | tub chair, tavolo allungabile | extendable table

GRACE / 834/PMC
poltroncina pozzetto | tub chair



GRACE / 834/P / 834
poltroncina | small armchair / sedia | chair







GRACE / 834/TC1
tavolo allungabile | extendable table

GRACE / 834/TO1
tavolo allungabile | extendable table





102

GRACE / 834/PB
poltrona | armchair



GRACE / 834/D
divano | sofa

103



DESIGN
RADICE ORLANDINI

poltroncina | small armchair

Coulisse

La poltroncina Coulisse manifesta la propria particolarità nella fascia posta sul retro dello schienale imbottito, curvo ed avvolgente, che va a creare un'originale arricciatura. Un dettaglio da sartoria che ne detta il sapore artigianale insieme alle gambe in massello di faggio che sorreggono la seduta.

The Coulisse small armchair shows its peculiarity in the band on the upholstered, wraparound curved backrest, creating an original curling. A tailored detail that gives it a touch of craftsmanship together with the legs in solid beech wood that support the seat.





COULISSE / 941/P
poltroncina | small armchair



COULISSE poltroncina | small armchair - DIVA tavolo allungabile | extendable table

DESIGN
MAURO LIPPARINI

tavoli allungabili | extendable tables

Aura

Il tavolo allungabile Aura si sviluppa a partire da un basamento in rovere a forma di croce, che ne costituisce l'elemento distintivo, abbinato ad un essenziale piano circolare o ovale della stessa essenza, per una proposta dall'estetica semplice, ma incisiva. Ad arricchire il progetto, si presenta il luminoso profilo in alluminio satinato che delinea la base.

The Aura extendable table develops from a cross shape oak base, which is its distinctive element, combined with an essential circular or oval top in the same wood essence, giving it a simple yet incisive look. The bright satin aluminum profile outlines the base giving to the table its special touch.



AURA

830/TC1
tavolo allungabile | extendable table



AURA

830/TO1
tavolo allungabile | extendable table



AURA tavolo allungabile | extendable table - GRACE poltroncina pozzetto | tub chair

DESIGN
MARIO FERRARINI

poltrona seduta intrecciata | woven seat armchair
poltrona seduta imbottita | upholstered seat armchair

Scheggia

Prodotto rappresentativo della maestria artigianale dell'azienda è la poltrona Scheggia, che prende idealmente forma da una linea continua in cui il disegno di schienale, braccioli e gambe in massello di noce Canaletto rastremato ai bordi, è dettato dalle venature stesse del legno. La seduta, intrecciata a mano, può essere in cordino "Gassa" color testa di moro, oppure interamente imbottita in tessuto o pelle.

A representative product of the company's craftsmanship is the Scheggia armchair, which ideally takes shape from a continuous line in which the design of the backrest, armrests and legs in solid Canaletto walnut tapered at the edges is dictated by the grain of the wood itself. The hand-woven seat can be in dark brown "Gassa" rope, or entirely upholstered in fabric or leather.





SCHEGGIA / 906/PLI
poltrona seduta imbottita | upholstered seat armchair

DESIGN
LUIS A. ARRIVILLAGA

tavolino | coffee table

Pocket

Pocket nasce dall'idea di creare un coffee table all'insegna della multifunzionalità. A comporre la sua struttura due tavolini di altezze differenti, a incastro: quello più alto con base in metallo e top laccato nero, il più basso con la stessa base metallica e piano contenitore in frassino che può essere utilizzato come cassetto o piano d'appoggio. Scomponendo la normale funzionalità del cassetto, il designer lo rende così un elemento indipendente.

Pocket was born from the idea of creating a coffee table in the name of multifunctionality. Its structure is composed of two interlocking coffee tables of different heights: the highest one with metal base and black lacquered top, the lowest with the same metal base and container top in ash wood that can be used as a drawer or top. By breaking down the normal functionality of the drawer, the designer makes it an independent element.

POCKET

894/TB
tavolino | coffee table





POCKET tavolino | coffee table - LÉNA poltrona girevole | swivel armchair

DESIGN
GABRIELE E OSCAR BURATTI

sedia | chair
poltroncina | small armchair
poltrona | armchair
poltrona girevole | swivel armchair

Léna

Disponibile nelle versioni sedia, poltroncina e poltrona, fissa con gambe in massello di frassino, e girevole con base centrale a quattro razze in alluminio, Léna propone una rilettura in chiave minimal contemporanea della classica seduta a pozzetto. Grazie alla particolare costruzione dello schienale, Léna elimina quasi completamente le cuciture creando una scanalatura che rende particolarmente funzionale la realizzazione della versione bimaterica.

Available in the chair and small armchair version, as well as armchair version, with solid ash wood legs or four-star swivel aluminum central base, Léna proposes a reinterpretation of the classic tub chair in a contemporary minimalist style. Thanks to the construction of the backrest, Léna eliminates the sewing almost completely, creating a groove which makes the construction of the bi-material version particularly functional.

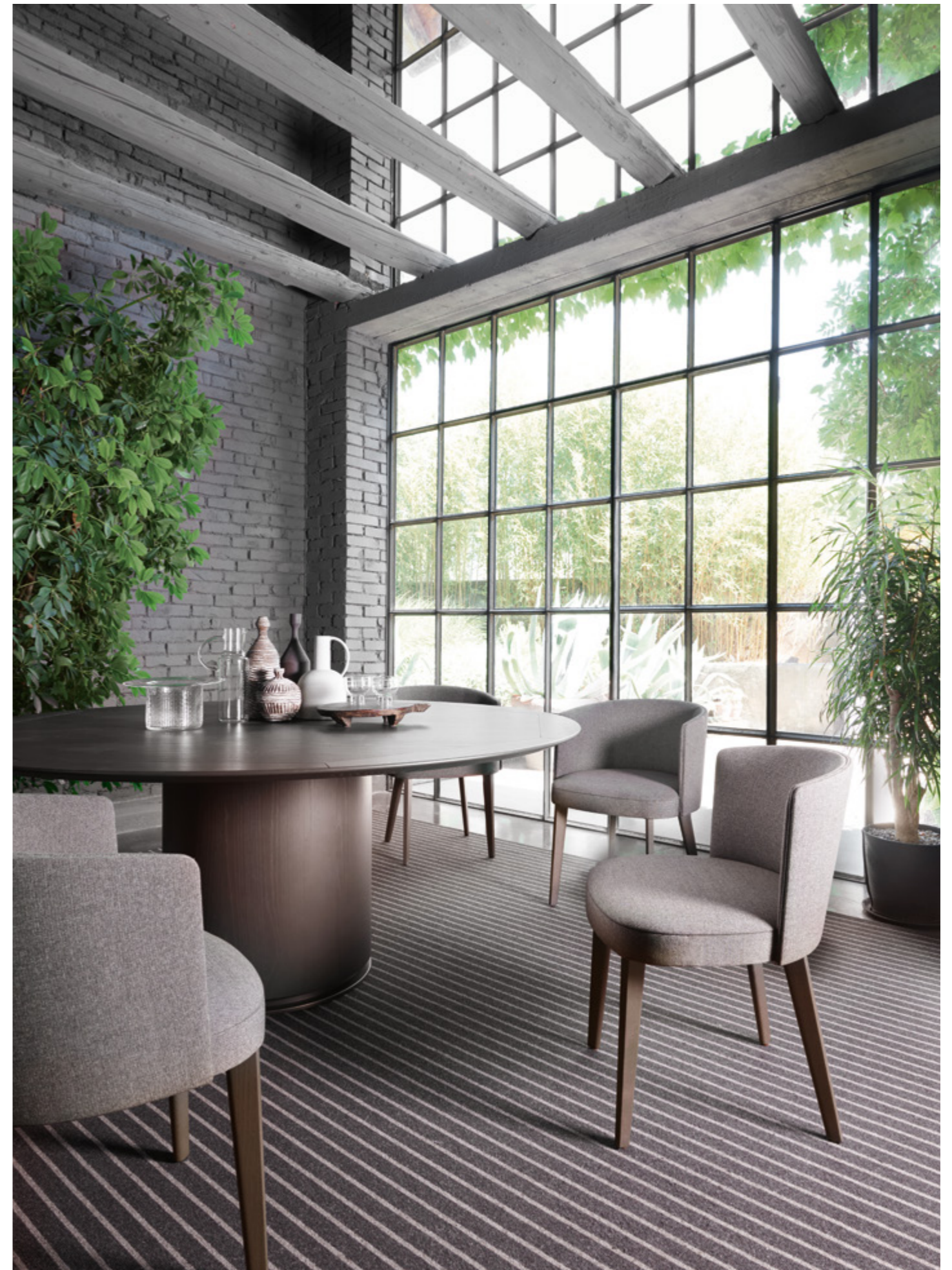

LÉNA sedia | chair, poltroncina | small armchair - OTAB tavolo | table



LÉNA / 903
 sedia | chair

LÉNA / 903/P
 poltroncina | small armchair



LÉNA

903/PLG
poltrona girevole | swivel armchair



128



LÉNA poltrona | armchair - TRAY tavolini | coffee tables

DESIGN
BERNHARDT & VELLA

sedia | chair
poltroncina | small armchair
sgabello alto | barstool
sgabelli up&down | up&down stools
poltrona | armchair
divano | sofa
tavolo allungabile | extendable table

Blossom

Blossom è una collezione composta da sedute e da un tavolo allungabile con struttura in frassino.

Famiglia dalle forme archetipiche, che si caratterizza per un utilizzo dosato di dettagli. Leggeri plissé, accennati come petali sulla parte interna dello schienale, contraddistinguono le sedute imbottite Blossom.

Se sedia, poltroncina, poltrona, divano e sgabello si distinguono per le increspature e la cucitura impunturata che ne impreziosiscono l'imbottitura, rivestita in tessuto o pelle, il tavolo rivela, nella semplicità del disegno, attente lavorazioni artigianali. Lo sgabello è disponibile nella versione fissa, con gambe in massello di frassino e nella versione girevole con sistema a gas che permette di regolarne l'altezza.

Blossom is a collection made up of seats and an extendable table, with ash wood structure.

Family with archetypal shapes, characterized by a measured use of details. Light pleats, hinted at like petals on the inside of the backrest, distinguish the Blossom upholstered seats.

If chair, small armchair, armchair, sofa and stool are characterized by the pleats that embellish the upholstery, covered in fabric or leather, the table reveals true craftsmanship in the simplicity of its design. The stool is available in the fixed version with solid ash wood legs and in the swivel version with gas lift system, allowing you to adjust its height.





BLOSSOM / 840/A
sgabello alto | barstool



BLOSSOM / 840/AP-GAS
840/A-GAS
sgabelli up&down | up&down stools



BLOSSOM / 840/A-GAS
840/AP-GAS
sgabelli up&down | up&down stools



BLOSSOM

840/TR1
tavolo allungabile | extendable table





BLOSSOM tavolo allungabile | extendable table, sedia | chair, poltroncina | small armchair



BLOSSOM / 840 / sedia | chair / 840/P / poltroncina | small armchair



BLOSSOM / 840/PL / poltrona | armchair



BLOSSOM / 840/D / divano | sofa



DESIGN
STORAGEMILANO

poltrona | armchair

Stay

La poltrona Stay presenta un'essenziale struttura in tondino di metallo, in ottone brunito o antracite goffrato, che abbraccia schienale e seduta: i due elementi, funzionalmente e visivamente svincolati l'uno dall'altro, sembrano galleggiare al suo interno conferendo una levità d'insieme. Dall'approccio contemporaneo ma con rimandi agli anni '50, Stay è caratterizzata da volumi squadrati ma ingentiliti lungo i profili dalle morbide curve dell'imbottitura che fa da contrappunto al rigoroso disegno della struttura.

Stay armchair has an essential structure in metal rod, in bronzed brass or anthracite finish, which embraces the backrest and seat: the two elements, functionally and visually released from one another, seem to float inside it giving a light levity to the project. With a contemporary approach but with references to the 1950s, Stay is characterized by squared volumes, softened along the profiles with the soft curves of the padding that acts as a counterpoint to the rigorous design of the structure.



STAY poltrona | armchair - POCKET tavolino | coffee table - SEN madia | sideboard

STAY 909/PL
poltrona | armchair



STAY poltrona | armchair - HISHI tavolini | coffee tables - ARIAL libreria | bookcase - TALE specchio | mirror

DESIGN
MARIO FERRARINI

sedie | chairs
poltroncine | small armchairs
sedie girevoli | swivel chairs
poltroncine girevoli | swivel small armchairs
sedie base cono girevoli | cone base swivel chairs
poltroncine base cono girevoli | cone base swivel small armchairs
sedie base slitta | sled base chairs
poltroncine base slitta | sled base small armchairs
sedie base cantilever | cantilever base chairs
poltroncine base cantilever | cantilever base small armchairs

Lyz

La sedia e la poltroncina Lyz mostrano la sapiente capacità dell'azienda nel lavorare il legno come materia viva mettendolo in relazione con diversi materiali. Un rapporto vicendevole dove il legno massello di frassino o noce Canaletto diventano la struttura su cui si sviluppa il rivestimento, disponibile nei tessuti e pelli di collezione, visibile da ogni angolazione della seduta. Disponibile con inserto in legno o interamente imbottita, questa seduta viene proposta anche con base girevole, cantilever, a slitta e a cono.

Lyz chair and small armchair show the company's craftsmanship in working wood as a live material in relationship with different others. A relationship in which solid ash wood or Canaletto walnut are the structure on which the padding comes to life, available in the coverings as per collection, visible through every angle. Available in the fully upholstered version or in the one with the visible wood insert, Lyz is also available with the swivel base, with the cantilever base, with the sled legs base and with the cone base.



LYZ sedia | chair, poltroncina | small armchair - OPUS tavolo | table - ARIAL consolle | console



LYZ / 918/P / poltroncina | small armchair / 918 / sedia | chair



LYZ sedia | chair, poltroncina | small armchair - OTAB tavolo | table - TALE specchio | mirror

LYZ

918/PG

poltroncina girevole | swivel small armchair

918/G

sedia girevole | swivel chair



150



151

LYZ sedia girevole | swivel chair, poltroncina girevole | swivel small armchair - OPUS tavolo | table - AVANT madia | sideboard

LYZ

918/PI
poltroncina | small armchair

918/I
sedia | chair



LYZ

918/PGCI
poltroncina base cono girevole |
cone base swivel small armchair

918/GCI
sedia base cono girevole |
cone base swivel chair



LYZ

918/PGC
poltroncina base cono girevole |
cone base swivel small armchair

918/GC
sedia base cono girevole |
cone base swivel chair



LYZ

918/PGI
poltroncina girevole | swivel small armchair

918/GI
sedia girevole | swivel chair



LYZ / 918/PSLI / poltroncina base slitta | sled base small armchair / 918/SLI / sedia base slitta | sled base chair



LYZ / 918/U / sedia base cantilever | cantilever base chair / 918/PU / poltroncina base cantilever | cantilever base small armchair



LYZ / 918/PSL / poltroncina base slitta | sled base small armchair / 918/SL / sedia base slitta | sled base chair



LYZ / 918/UI / sedia base cantilever | cantilever base chair / 918/PUI / poltroncina base cantilever | cantilever base small armchair



DESIGN
DAVID LOPEZ QUINCOCES

poltrona | armchair
divani | sofas
divano componibile | modular sofa
daybed | daybed

Loom

Ispirazione retrò per la collezione Loom composta da divano, poltrona e daybed. Minimalismo e semplicità definiscono il progetto: a disegnarne il profilo, è presentata un'essenziale cornice in massello di mogano con inserto in giunco intrecciato a tela, eco di una tradizione artigianale ed espressione di una profonda abilità manuale. La collezione è disponibile anche nella versione per esterni con intreccio in corda.

A retro inspiration for the Loom collection, consisting of sofa, armchair and daybed. Minimalism and simplicity define the project: to draw its profile, an essential frame in solid mahogany wood with a cane woven insert, echo of an artisan tradition and expression of profound manual skill. The collection is also available in the outdoor version with rope weaving.



LOOM
880/PC
poltrona | armchair



LOOM daybed | daybed - LITTLE T tavolino | coffee table



LOOM poltrona | armchair - LITTLE T tavolino | coffee tables



LOOM

880/DB
daybed | daybed



LOOM divano | sofa - HERM pouf | pouf - LITTLE T tavolino | coffee table



LOOM / 880/DC
divano | sofa



LOOM / 880/DC
divano | sofa



LOOM divano | sofa - LITTLE T tavolino | coffee table - VIGO lounge | lounge chair



LOOM

880/DCL, 880/DCM
divano componibile | modular sofa



LOOM poltrona | armchair, divano componibile | modular sofa - TRAY tavolini | coffee tables - ROPU tavolini | coffee tables

DESIGN
GIANLUIGI LANDONI

tavoli | tables
sgabello up&down | up&down stool

Torso

Famiglia di tavoli e sgabello up&down. Incroci di legno che si ergono su delicati piedini metallici caratterizzano i tavoli della collezione Torso. Un progetto insieme essenziale e sofisticato, un divertissement con cui l'azienda esprime liberamente la maestria nella lavorazione del legno piegando il materiale alla propria volontà.

Gli sgabelli dal design moderno e minimale si adattano ad ogni contesto domestico così come in bar e ristoranti.

Family of tables and up & down stool. Wooden crosses that rise on delicate metal feet characterize the tables of the Torso collection. A project that is both essential and sophisticated, a divertissement with which the company freely expresses its mastery in woodworking by bending the material to its will.

The stools with a modern and minimal design adapt to any context, from the domestic one as well as in bars and restaurants.



TORSO

837/A-GAS
sgabello up&down | up&down stool



TORSO / 837/TR
tavolo | table



TORSO / 837/T4
tavolo | table



DESIGN
CHIARA ANDREATTI

tavolini | coffee tables
pouf | pouf

Ropu

Dalle rimembranze esotiche, Ropu si distingue per la bordatura intrecciata a mano in cordino di cuoio e cordino "Gassa", che corre lungo il perimetro creando una cornice per top in marmo, vetro temperato retro verniciato, grès porcellanato e HPL oppure soffici cuscini con profili a coda di topo.

Con base a quattro gambe in metallo, la collezione è disponibile nella versione tavolino basso con piano rettangolare o alto con piano tondo e pouf rettangolare, da abbinare in libere composizioni. Ropu è disponibile anche nella versione outdoor.

From exotic remembrances, Ropu stands out for its sophisticated woven border in hide rope, for indoor spaces, or "Gassa" rope, for the outdoor, running along the perimeter structure creating a frame for marble, back-painted tempered glass, laminated porcelain and HPL tops or soft cushions with mousetail cord profiles.

With a four-legged metal base, the collection consists of a low coffee table with rectangular top or a high coffee table with circular top and rectangular pouf, to combine in free compositions. Ropu is also available in the outdoor version.



ROPU

888/CQR-IN
pouf | pouf



ROPU / 888/TBR / 888/TBC
 tavolino | coffee table / tavolino | coffee table



ROPU tavolini | coffee tables, pouf | pouf - VIGO lounge | lounge chair

DESIGN
GIANLUIGI LANDONI

pouf | poufs

Herm

Un dettaglio sartoriale contraddistingue il pouf Herm: una fascia in tessuto o pelle con cuciture a vista lo circonda creando raffinati plissé. È dotato di una pratica maniglia, che ne agevola lo spostamento. Proposto in tre diverse forme, Herm è disponibile sia nella versione indoor, per creare diverse composizioni in un interno domestico, sia nella variante outdoor, per personalizzare terrazze e giardini.

A tailored detail distinguishes the Herm pouf: a belt in fabric or leather with visible stitching, surrounds the pouf to create fine pleats. A practical handle is fitted facilitating its movement. Available in 3 different shapes, Herm is available both in the indoor version, to create different compositions in a domestic interior, and in the outdoor version, to customize terraces and gardens.



HERM

925/O45
pouf | pouf

925/O80
pouf | pouf

925/O60
pouf | pouf



HERM pouf | poufs



HERM pouf | pouf

DESIGN
CHIARA ANDREATTI

tavolini | coffee tables

Hishi

La base in ceramica smaltata grigio sabbia e pesca, caratterizzata da un decoro a bassorilievo a maglia geometrica realizzato artigianalmente, che attraverso il deposito della cristallina crea ricercati effetti cromatici, contraddistingue la famiglia di tavolini Hishi.

Proposti in due altezze, sono disponibili con piano circolare o quadrato in vetro bronzo temperato o noce Canaletto.

I tavoli Hishi sono adatti anche per un ambiente outdoor.

The base in sand grey and peach ceramic, characterized by a hand-crafted geometric-patterned bas-relief decoration, which through the deposit of the crystalline creates refined chromatic effects, distinguishes the Hishi coffee tables' family.

Available in two heights, they are proposed with round or square top in bronzed tempered glass or Canaletto walnut.

The Hishi coffee tables are suitable also for outdoor ambiances.



HISHI tavolini | coffee tables - LÉNA poltrona girevole | swivel armchair



HISHI

871/TBC
 tavolino | coffee table

871/TBQ
 tavolino | coffee table



HISHI tavolini | coffee tables - STAY poltrona | armchair - ARIAL libreria | bookcase - TALE specchio | mirror

DESIGN
STUDIO MARCO VIOLA

divano componibile | modular sofa
poltrona | armchair

Purple

La famiglia di imbottiti Purple, composta da divano componibile e poltrona, si contraddistingue per la soffice e avvolgente cuscineria sfoderabile in tessuto o pelle, che funge da schienale e seduta per il massimo comfort. Il divano Purple permette di declinare e combinare i singoli moduli in base alle specifiche necessità. Profili irregolari donano a Purple un aspetto fresco, rendendolo adatto ad un doppio utilizzo indoor e outdoor, dalla casa al contract.

The Purple upholstered family, composed of modular sofas and armchair, is characterized by the soft and curved cushioning with removable fabric or leather covers, serving as a backrest and seat for the maximum comfort. The Purple sofa allows you to decline and combine the individual modules according to specific needs. Irregular profiles give Purple a fresh look, making it suitable for a double use, both indoors and outdoors, from home to contract ambiances.



PURPLE

935/P
poltrona | armchair



PURPLE

935/D
divano componibile | modular sofa





PURPLE divano componibile | modular sofa - TRAY tavolini | coffee tables

DESIGN
MAURO LIPPARINI

tavolini | coffee tables
pouf | poufs

Rondò

L'elemento caratterizzante del tavolino Rondò è il rovere, lavorato in listelli verticali ripetuti e disposti a formare un cilindro. Rondò è disponibile, inoltre, con cuscino di seduta in tessuto o pelle che, da pratico coffee table, lo trasforma in un comodo pouf.

The characterizing element of the Rondò coffee table is the oak wood, worked in repeated vertical strips and arranged to form a cylinder. Rondò is also available with a seat cushion in fabric or leather which, from a practical coffee table, transforms it into a comfortable pouf.

RONDÒ

827/TB
tavolino | coffee table

827/TM
pouf | pouf

827/TM
tavolino | coffee table



DESIGN
ALEXANDER LORENZ

pouf | pouf

Dance

Partendo da una struttura a base quadrata, il pouf Dance abbandona la forma classica per trasformarsi in una scultura dinamica, in cui il movimento che lo caratterizza prende vita a partire dal rivestimento in tessuto o pelle e dalla torsione dell'involucro.

Starting from a square-based frame, the Dance pouf abandons the classic shape to evolve into a dynamic sculpture, in which the movement that characterizes it comes to life starting from the covering in fabric or leather and the twisting of the casing.



DANCE pouf | pouf

DESIGN
STEPHAN VEIT

sedia | chair
poltroncina | small armchair

Concha

Elemento distintivo della sedia e poltroncina Concha è l'avvolgente schienale imbottito e leggermente inclinato, la cui forma ne ha ispirato il nome. Con gambe in massello di rovere, Concha presenta linee essenziali che la rendono adatta ad ambienti domestici e spazi contract all'insegna della massima versatilità.

A distinctive feature of the Concha chair and small armchair is the enveloping, slightly inclined backrest, whose shape has inspired its name. With solid oak wood legs, Concha features essential lines that make it suitable for domestic environments and contract spaces for the maximum versatility.

CONCHA

905/P
poltroncina | small armchair

905
sedia | chair





CONCHA sedia | chair, poltroncina | small armchair - BON BON tavolo | table - AVANT madia | sideboard - STILLA specchio | mirror

DESIGN
SERENA CONFALONIERI

sgabelli up&down | up&down stools

Plissé

A partire dalla semplice base rotonda della seduta, lo sgabello Plissé si impreziosisce grazie a un dettaglio di sartoria: una plissettatura che corre lungo tutto il bordo, giocando sugli accostamenti tra tessuti e pelli differenti. Un dettaglio rubato al mondo della moda che asseconda le forme dello sgabello senza intaccarne l'elegante essenzialità. Lo sgabello Plissé, disponibile con e senza schienale, è regolabile in altezza con sistema a gas.

Starting from the simple round base of the seat, the Plissé stool is embellished thanks to a tailor-made detail: a pleating that runs along the entire edge, playing on the combinations of different fabrics and leathers. A detail stolen from the world of fashion that follows the shapes of the stool without affecting its elegant essentiality. The Plissé stool, available with or without backrest, is adjustable in height with gas lift system.



PLISSÉ

929/A-GAS
sgabello up&down | up&down stool

929/S-GAS
sgabello up&down | up&down stool



PLISSÉ sgabello up&down | up&down stool - OTX tavolo | table



PLISSÉ sgabello up&down | up&down stool - OTX tavolo | table

DESIGN
DAVID LOPEZ QUINCOCES

lounge | lounge chair

Vigo

La lounge Vigo reinterpreta il mondo dei grandi safari anni '20/'30 in chiave moderna, lavorando sui tubolari in metallo e sul cuoio pieno fiore auto portante, riportando al minimo tutti gli spessori. La leggera seduta accompagna dolcemente il corpo per godere dei momenti di massimo relax.

The Vigo lounge chair reinterprets the world of the great 20s / 30s safari in a modern way, working on metal tubular frames and self-supporting full-grain leather, keeping all thicknesses to a minimum. The light seat gently accompanies the body to enjoy moments of maximum relaxation.



DESIGN
RODRIGO TORRES

poltroncina | small armchair

Memory

La poltroncina Memory è un omaggio alla lavorazione tradizionale del legno che contraddistingue da sempre l'azienda. L'ergonomico schienale, che sembra appoggiarsi alla struttura massello in frassino, fa di Memory un arredo versatile e ideale per tutti gli ambienti della casa, così come per un ufficio o luoghi pubblici dedicati all'accoglienza. Memory è disponibile nei tessuti e pelli a collezione.

The Memory small armchair is a tribute to the traditional craftsmanship that has always distinguished the company. The ergonomic backrest, which seems to lean on the solid ash wood structure, makes Memory a versatile and ideal piece of furniture for all the rooms of the house, as well as for an office or public places dedicated to hospitality. Memory is available in the fabrics and leathers as per collection.

MEMORY

842/P
poltroncina | small armchair





DESIGN
MARIO FERRARINI

tavolo | table
tavolo allungabile | extendable table

Pipe

Famiglia di tavoli dallo stile architettonico. Pipe è disponibile nella versione con ampio piano rettangolare oppure con piano circolare allungabile e basamento circolare. Ad animarne la silhouette, la struttura composta da gambe in frassino nelle finiture a collezione che terminano in una base in tubolare nella finitura ottone brunito.

Family of tables with an architectural style. Pipe is available in the version with a large rectangular top or with an extendable circular top and circular base. To animate its silhouette, the structure composed of ash wood legs in the finishes as per collection that ends in a tubular base in a bronzed brass finish.





PIPE tavolo | table - AVANT madia | sideboard - MEMORY poltroncina | small armchair



PIPE / 885/TC
 tavolo allungabile | extendable table



PIPE tavolo allungabile | extendable table - LARS sedia | chair - SEN madia | sideboard

DESIGN
GABRIELE E OSCAR BURATTI

madie | sideboards
credenza | cabinet

Avant

Avant, famiglia di contenitori composta da madia, con gambe in due altezze, e credenza. Un volume rigoroso che vive del calore e delle vibrazioni date dal movimento naturale del frassino e del noce Canaletto, materiale vivo scelto per disegnare le forme di questa collezione. Elemento funzionale ed estetico distintivo del progetto è il bordo superiore massellato delle ante battenti e dello schienale, che sovrasta lievemente il piano, consentendo la presa e l'apertura delle ante eliminando la presenza di maniglie. All'interno, ripiani in vetro retro verniciato nero temperato e su richiesta cassetti centrali per la credenza, e posizionati in alto per la madia. Una proposta che combina tradizione a tocchi industriali ricercati: le cerniere a chiusura ammortizzata sono state accuratamente selezionate per il loro impatto estetico minimo che permette così di celare il meccanismo alla vista. Completa il progetto il dettaglio delle essenziali gambe in ottone brunito.

Avant, family of containers consisting of a sideboard, with legs in two heights, and a cabinet. A rigorous volume that lives on the warmth and vibrations given by the natural movement of the ash wood and Canaletto walnut, a living material chosen to design the shapes of this collection. A distinctive functional and aesthetic element of the project is the solid wooden upper edge of the hinged doors and the back, which slightly overhangs the top, allowing the doors to be gripped and opened, eliminating the presence of handles. Inside, black back painted tempered glass shelves and, on request, central drawers for the cabinet, and positioned at the top for the sideboard. A proposal that combines tradition with sophisticated industrial touches: the soft closing hinges have been carefully selected for their minimal aesthetic impact, allowing the mechanism to be hidden from view. The detail of the essential bronzed brass legs completes the project.



AVANT

884/MA
credenza | cabinet



AVANT credenza | cabinet - CONCHA sedia | chair, poltroncina | small armchair - OTAB tavolo | table



AVANT

884/MB2-180
madia | sideboard







AVANT

884/MB2
madia | sideboard



AVANT

884/MB1
madia | sideboard

DESIGN
BERNHARDT & VELLA

sedia | chair
poltroncina | small armchair

Candy

Sedia e poltroncina compongono la famiglia Candy, costituita da una cornice, dalle proporzioni misurate, in cui si incontrano la base in massello di frassino e l'imbottitura all'altezza della seduta, diventando un tutt'uno con essa.

Candy può essere personalizzata grazie ai rivestimenti in tessuto o pelle disponibili a collezione. Disponibile anche nella versione capitonné, si adatta così a tutti i contesti, dalla casa all'ufficio, ma anche a spazi collettivi quali hotel e ristoranti fino ad un raffinato ambiente domestico.

Chair and small armchair make up the Candy family, consisting of a frame, with measured proportions, where the solid ash wood base and the padding at the seat's height meet, becoming one.

Candy can be customized thanks to the fabric or leather upholstery available as per collection. Available also in the capitonné version, it adapts to all contexts, from the home to the office, but also to collective spaces such as hotels and restaurants to a refined home environment.



CANDY poltroncina | small armchair



CANDY

943/P
poltroncina | small armchair

943
sedia | chair



DESIGN
ALEXANDER LORENZ

tavolo | table

Anfora

Dall'aspetto scultoreo, il tavolo Anfora individua il proprio tratto distintivo nell'iconica base, la cui forma, ispirata all'antico vaso greco, ne determina il nome. Proposta dall'estetica ricca, Anfora è caratterizzato da profili morbidi e sinuosi che richiamano il movimento di una figura danzante.

From the sculptural appearance, the Anfora table identifies its distinctive feature in the iconic base, whose shape, inspired by the ancient Greek vase, determines its name. With its rich aesthetics, Anfora is characterized by soft and sinuous profiles that recall the movement of a dancing figure.





ANFORA / 879/T
tavolo | table



ANFORA tavolo | table - VELIS poltroncina pozzetto | tub chair



Base quarzo resinato Light Grey e piano marmo Carrara.
Light Grey resinated quartz base, Carrara marble top.



Base quarzo resinato Antracite e piano marmo Grigio Carnico.
Anthracite resinated quartz base, Grigio Carnico marble top.



Base quarzo resinato Light Grey e piano marmo Carrara.
Light Grey resinated quartz base, Carrara marble top.

238



Base quarzo resinato Light Grey e piano marmo Grigio Carnico.
Light Grey resinated quartz base, Grigio Carnico marble top.

239



Base quarzo resinato Antracite e piano marmo Grigio Carnico.
Anthracite resinated quartz base, Grigio Carnico marble top.



Base quarzo resinato Antracite e piano marmo Carrara.
Anthracite resinated quartz base, Carrara marble top.

DESIGN
FAVARETTO & PARTNERS

sedia lounge | lounge chair

Track

Riprendendo le tipiche sezioni della lavorazione del legno degli anni '50, Track presenta una struttura in frassino o noce Canaletto a forma di "y" rovesciata. Dalle dimensioni generose, questa sedia lounge è pensata per un angolo relax, così come in una camera da letto grazie a una seduta e schienale caratterizzati da una confortevole imbottitura. Una proposta dalla presenza importante che imprime un segno molto forte all'ambiente in cui è inserita.

Recalling the typical woodworking sections of the 1950s, Track has a structure in ash wood or Canaletto walnut in the shape of an inverted "y". This lounge chair, with generous dimensions, is thought for a relaxing space or for a bedroom, thanks to its comfortable seat and backrest padding. A proposal with an important presence that gives a very strong mark to the environment in which is inserted.



TRACK sedia lounge | lounge chair - HISHI tavolini | coffee tables

TRACK

919/L
sedia lounge | lounge chair



242



243

TRACK sedia lounge | lounge chair - POCKET tavolino | coffee table - TALE specchio | mirror

DESIGN
GABRIELE E OSCAR BURATTI

consolle | console
librerie autoportanti | freestanding bookshelves

Arial

Arial è una collezione di librerie autoportanti e consolle che sceglie il legno come materiale d'eccellenza abbinato a materiali più tech. Linee pure ed essenziali per la libreria Arial, caratterizzata da un telaio molto tirato e dalla sezione ridotta, in metallo ottone brunito o antracite goffrato, con piedini in contrasto.

Ideale a parete, così come al centro di una stanza, per una partizione delicata ed elegante degli ambienti.

Minimalismo e dettagli sofisticati caratterizzano la consolle Arial che reinterpreta l'arredo domestico d'accoglienza. A contraddistinguerla, la parte superiore dei cassetti e dello schienale, realizzata in massello di frassino o noce Canaletto, che sovrasta leggermente il piano disponibile in marmo, vetro retro verniciato temperato, frassino o noce Canaletto, creando una sorta di vassoio.

Arial is a collection of freestanding bookshelves and console that chooses wood as a material of excellence combined with more tech materials. Sinuous and pure lines for the Arial bookcase, characterized by a very tight frame and reduced section, in bronzed brass or anthracite embossed metal, with contrasting feet.

Ideal endorsed on walls, as well as in the center of the room, for a delicate and elegant partition of the ambiances. Minimalism and sophisticated details characterize the Arial console that reinterprets the home decor. To distinguish it, the upper part of the drawers and back, made of solid ash wood or Canaletto walnut, slightly overhanging the top, available in marble, back-painted tempered glass, ash wood or Canaletto walnut, creating a sort of tray.



ARIAL | 870/CS
consolle | console



ARIAL consolle | console, libreria | bookcase - OTAB tavolo | table - CONCHA sedia | chair, poltroncina | small armchair





ARIAL / 870/MS
 libreria autoportante | freestanding bookcase



ARIAL libreria autoportante | freestanding bookcase - TALE specchio | mirror



ARIAL

870/ML
libreria autoportante | freestanding bookcase



ARIAL libreria autoportante | freestanding bookcase - OPUS tavolo | table - VELIS poltroncina | small armchair

DESIGN
STORAGEMILANO

specchio autoportante | freestanding mirror

Tale

Lo specchio Tale è un complemento dal segno grafico ma di grande forza espressiva che gioca sull'interazione tra volumi geometrici, apparentemente liberi ma legati tra loro. La cornice sembra infatti volersi svincolare dallo specchio, scomponendolo su più piani e creando l'illusione di un oggetto in costante ricerca di equilibrio e stabilità. La base e l'archetto in finitura ottone brunito o antracite goffrato, sono abbinati a una cornice in metallo verniciato antracite goffrato.

Tale mirror is an interior design complement with a very strong graphic sign that plays on geometric volumes, apparently free, but linked together. It seems like its frame wants to untie itself from the mirror, breaking it down on different levels, creating the illusion of an object constantly searching for stability and equilibrium. The base and the lower band, in bronzed brass or anthracite embossed metal, are combined with a frame in anthracite embossed painted metal.



TALE specchio autoportante | freestanding mirror - ARIAL libreria | bookcase - STAY poltrona | armchair



TALE

891/S
specchio autoportante | freestanding mirror

TALE specchio autoportante | freestanding mirror - OPUS tavolo | table - VELIS poltroncina | small armchair

DESIGN
STUDIO MARCO VIOLA

tavolini | coffee tables

Tray

Il set di tavolini Tray si presta in varie combinazioni grazie alle diverse forme, altezze e finiture disponibili. L'essenziale struttura in metallo che viene modulata in base alle dimensioni del tavolino, sorregge il piano in marmo o vetro temperato retro verniciato, incorniciato da un bordo in frassino curvato che va a creare una sorta di vassoio.

The Tray Coffee tables' set is a versatile collection, presented in different combinations of shapes, heights and finishes. The essential metal structure that is modulated according to the size of the table, supports the top in marble or back painted tempered glass, framed by a curved ash wood edge that creates a sort of tray.

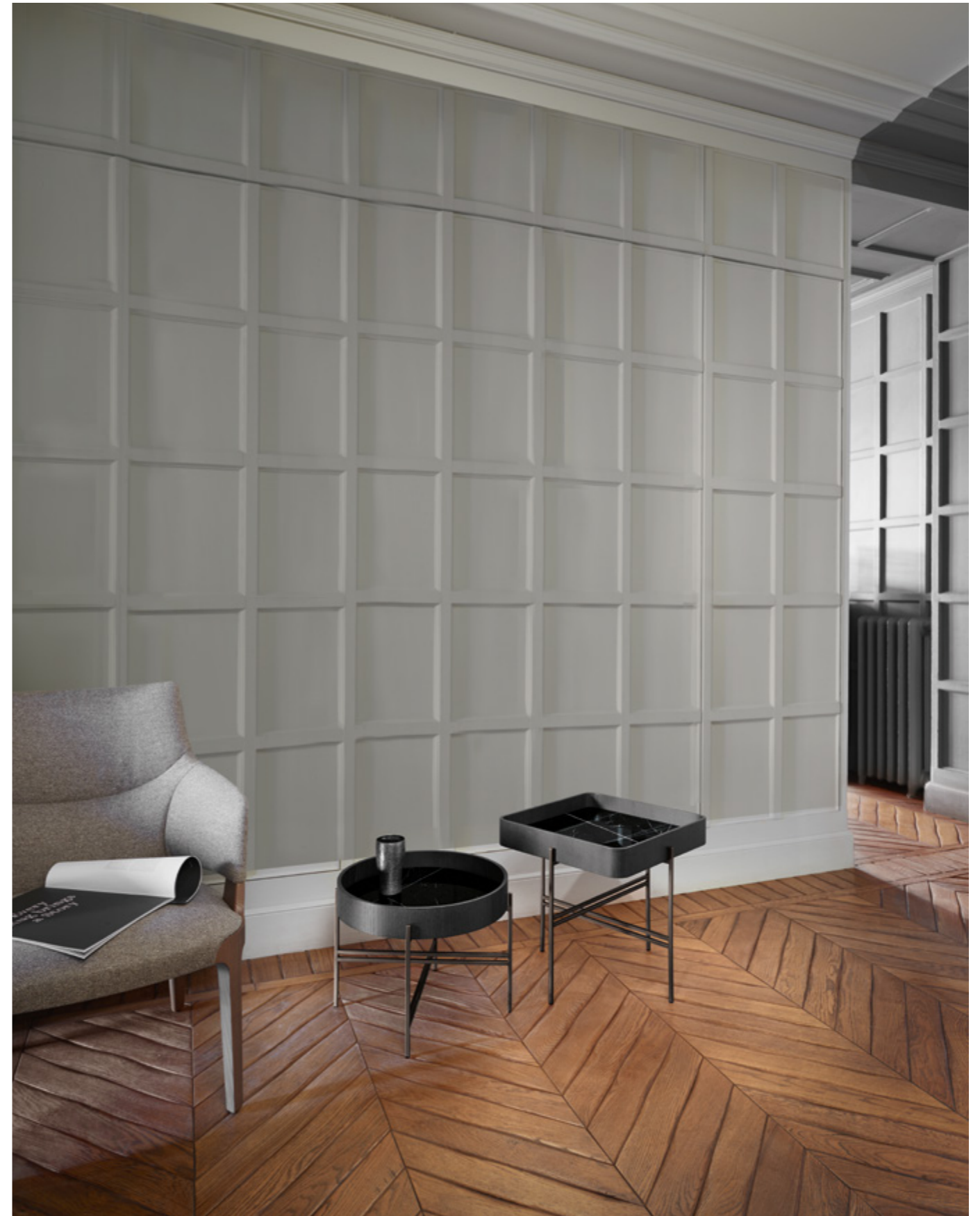

TRAY tavolini - coffee tables - VELIS poltrona | armchair



TRAY

872/TR
tavolino | coffee table



TRAY

872/TC
tavolini | coffee tables



TRAY

872/TQ
tavolini | coffee tables

DESIGN
STEPHAN VEIT

bergère | bergère
bergère girevole e reclinabile | swivel and reclining bergère
pouf | poufs

Cut

Cut nasce dalla volontà di sviluppare una seduta dalle forme ergonomiche e avvolgenti. Il risultato è una bergère dall'aspetto leggero ed estremamente confortevole, grazie anche ai cuscini di seduta e poggiatesta a due regolazioni, sostenuta da un'essenziale base in alluminio verniciato nero goffrato, proposta in due versioni: fissa e girevole a quattro razze. La versione girevole è reclinabile con blocco in 5 posizioni. I profili netti e le cuciture a vista in corrispondenza delle incisioni conferiscono alla seduta un look tailor-made. Accompagna la bergère l'omonimo poggiapiedi, con base fissa e a quattro razze, che ne riprende le caratteristiche estetiche.

Cut comes from the desire to create a seating with ergonomic and embracing wrapping forms. The result is a bergère with a light and extremely comfortable look, thanks also to its seat and headrest cushions, with two settings, supported by an essential embossed black painted aluminum base, available in two versions: fixed and swivel four-star base. The swivel version can be reclined with a block in 5 positions. The net profiles and the visible stitching in correspondence of the incisions give the seat a tailor-made look. The homonymous footrest, available with a fixed or swivel four-star base, accompanies the bergère, resuming its aesthetic characteristics.



CUT bergère girevole e reclinabile | swivel and reclining bergère, pouf | pouf - STILLA specchio | mirror - SEN madia | sideboard



CUT / 910/PP / 910/PL
 pouf | pouf / bergère | bergère



CUT / 910/PPG / 910/PLG
 pouf | pouf / bergère girevole e reclinabile | swivel and reclining bergère



CUT bergère | bergère, pouf | pouf - TRAY tavolini | coffee tables - AVANT madia | sideboard - ARIAL libreria | bookcase

DESIGN
STEPHAN VEIT

sgabello alto | barstool
tavolo allungabile | extendable table
scrittoio | writing desk

Linus

La collezione Linus, composta da sgabello, scrittoio e tavolo allungabile in due misure, presenta linee aeree e agili in cui la lavorazione del legno si unisce a dettagli impeccabili: dal sistema di estensione del tavolo, alle cuciture perimetrali a vista del piano in cuoietto dello scrittoio, che dichiarano l'artigianalità alla base progetto.

The Linus collection, consisting of a stool, a writing desk, and an extendable table in two dimensions, presents airy and agile lines in which the woodwork is combined with impeccable details: from the table extension system to the visible perimeter seams of the hide leather writing desk's top, which declare the craftsmanship behind the project.





LINUS / 730/SCR
scrittoio | writing desk



LINUS / 730/AI
sgabello alto | barstool

LINUS

730/TC1
tavolo allungabile | extendable table



LINUS tavolo allungabile | extendable table



DESIGN
BERNHARDT & VELLA

poltrona | armchair

Yoisho

Poltrona ultrasoft dalle linee sinuose, Yoisho crea un nido di relax contemporaneo grazie all'imbottitura a tutto tondo e alla cuscineria molto alta della seduta. Le cuciture a vista lasciano trasparire l'abilità artigianale dell'azienda e l'attenzione estrema ai dettagli come il bordo inferiore della seduta in legno finitura ottone brunito.

The Yoisho ultra-soft armchair, with its sinuous lines, creates a contemporary nest for relaxation, thanks to the all-round padding and the very deep seat cushions for the maximum comfort. The visible stitching reveals the company's craftsmanship and extreme attention to details, such as the lower edge of the wooden seat with bronzed brass finish.

YOISHO

904/PL
poltrona | armchair



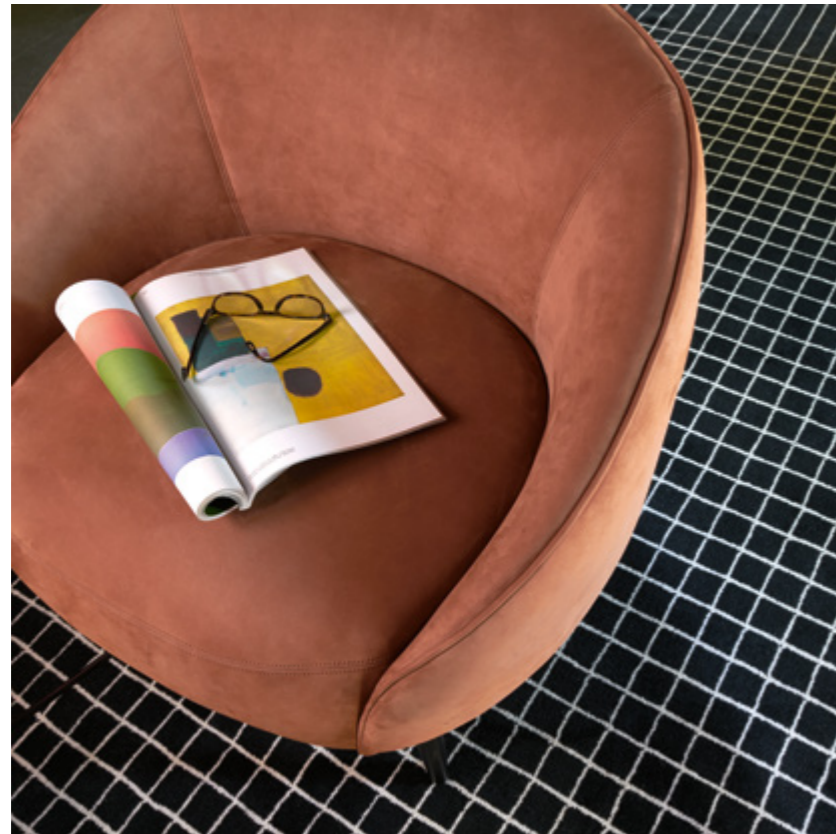

YOISHO poltrona | armchair - SEN credenza | cabinet - LITTLE T tavolino | coffee table

DESIGN
CHIARA ANDREATTI

divano | sofa

Elodie

Il divano a due posti Elodie è caratterizzato da una struttura essenziale a vista, pensata per accogliere gli ampi cuscini che appoggiano su una lama piatta in metallo che corre tutto intorno alla cuscineria sorreggendola. Dettaglio distintivo il cuscino di seduta, che grazie a dei particolari sostegni si distacca dalla struttura risultando sospeso. L'imbottitura e il rivestimento sono realizzati sia con materiali adatti all'utilizzo in contesti indoor che outdoor.

The Elodie two-seater sofa is characterized by an essential exposed structure, designed to accommodate the large cushions that rest on a flat metal profile that runs all around the cushions supporting it. A distinctive detail is the seat cushion, which thanks to supports detaches itself from the structure appearing suspended.

The padding and upholstery are made with materials suitable for both indoor and outdoor settings.



ELODIE

908/D
divano | sofa



ELODIE divano | sofa - ROPU tavolini | coffee tables, pouf | pouf

DESIGN
CHIARA ANDREATTI

consolle a parete | wall console
consolle | console
scrittoio | writing desk

Wood_Y

Dall'impronta minimal, la collezione Wood_Y è composta da consolle autoportante e consolle a parete, pensate per completare la zona living, l'ingresso o il corridoio, e da uno scrittoio con l'opzionale dettaglio del cassetto sotto piano nella stessa finitura del mobile. L'intera struttura è realizzata in massello di frassino, arricchita da dettagli in ottone brunito.

A proposal with a minimalist design, the Wood_Y collection is made of freestanding and wall consoles designed to complete the living area, the entrance hall or corridor, and a writing desk with the optional detail of the drawer under the top, in the same finish as the furniture item. The entire structure is built in solid ash wood, embellished by small, bronzed brass details.



WOOD_Y scrittoio | writing desk - VELIS sedia | chair



WOOD_Y consolle a parete | wall console - LOOM poltrona | armchair - LITTLE T tavolino | coffee table



WOOD_Y / 889/CS
consolle a parete | wall console

WOOD_Y

889/CSF
consolle | console



282

WOOD_Y

889/SCR
scrittoio | writing desk

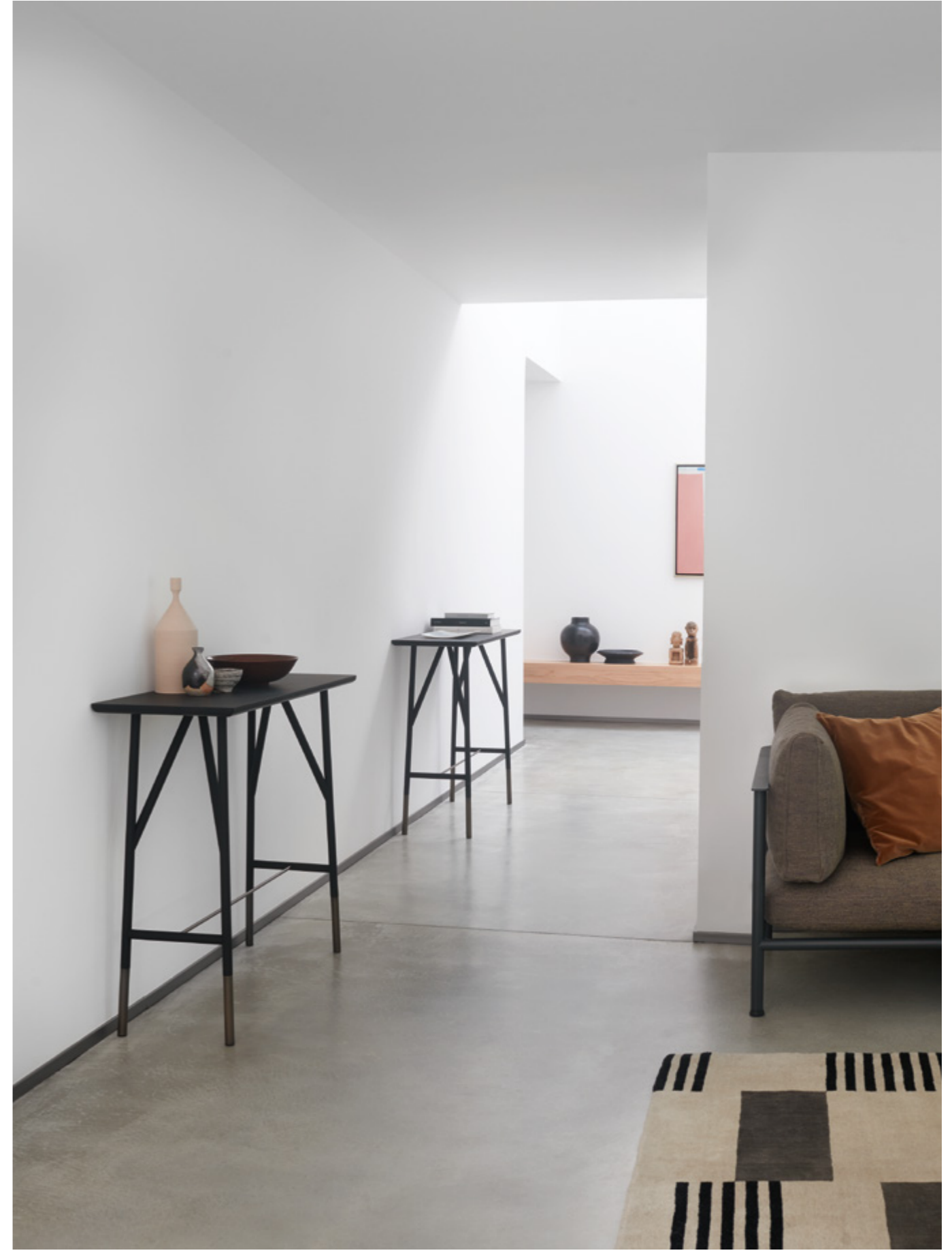

283

WOOD_Y consolle | console - ELODIE divano | sofa

DESIGN
CHIARA ANDREATTI

credenza | cabinet
madia | sideboard

Sen

Famiglia di contenitori composta da madia e credenza, Sen si ispira al disegno delle tradizionali porte giapponesi in carta di riso. Il disegno del volume in frassino, disponibile in tutte le finiture di collezione, si stempera nella leggerezza visiva data dall'incrocio di griglie in massello di frassino, applicate ad ante scorrevoli in vetro temperato bronzo o trasparente che celano piani interni a diverse altezze.

Family of containers composed of sideboard and cabinet. Sen is inspired by the design of the traditional Japanese doors in rice paper. The design of the ash wood volume, available in the finishes as per collection, tones down thanks to the visual lightness created by the crossed grilles in solid ash wood attached to sliding doors in tempered bronzed or transparent glass, hiding internal shelves at different heights.



SEN credenza | cabinet - OTAB tavolo | table - VELIS sedia | chair



SEN / 886/MB
 madia | sideboard





SEN madia | sideboard - VIGO lounge | lounge chair - ROPU tavolino | coffee table - STILLA specchio | mirror

LITTLE T tavolino | coffee table - LOOM divano | sofa

DESIGN
BERNHARDT & VELLA

bergère | wing chair
pouf | pouf
divano | sofa
tavolini | coffee tables

Spring

Bergère, divano, pouf e tavolini compongono la collezione Spring. L'elemento di distinzione delle sedute risiede nella comune base con bassi piedini in massello di faggio. Divano e bergère presentano, inoltre, alti schienali e un'imbottitura dal forte spessore, rivestita a scelta in tessuto o pelle e anche in versione bimatrica. I tavolini in massello di frassino, disponibili in tre dimensioni e forme, hanno il piano in frassino, marmo o vetro temperato retro verniciato con cornice in legno.

Wing chair, sofa, pouf, and coffee tables compose the Spring collection. The distinguishing element of the seating resides in the common base with solid beech wood feet. The sofa and the wing chair also feature high backrests and thick padded upholstery in a selection of fabrics or leathers, available also in the bi-material version. The coffee tables in solid ash wood, available in three sizes and shapes, have a top in ash wood, marble, or tempered back-painted glass with wooden frame.





SPRING | 841/P bergère | wing chair | 841/S pouf | pouf

SPRING | 841/TBC tavolino | coffee table | 841/TBQ tavolino | coffee table



SPRING | 841/D divano | sofa

SPRING | 841/TBR tavolino | coffee table





SPRING divano | sofa, bergère | wing chair, tavolini | coffee tables

DESIGN
ENRICO FRANZOLINI

sedia | chair
poltroncina | small armchair

Greta

Dal disegno rigoroso e geometrico, Greta si distingue per i volumi imbottiti pieni ed accoglienti e per un design essenziale ma attento ai dettagli e al comfort. Una proposta perfetta per accompagnare ogni tavolo da pranzo così come per arredare sofisticate meeting room. La famiglia Greta si compone di sedia e poltroncina in massello di rovere. Disponibile anche in versione sfoderabile.

With a rigorous and geometric design, Greta stands out for its full and welcoming padded volumes and for an essential design that is attentive to details and comfort. A perfect proposal to accompany any dining table as well as to furnish sophisticated meeting rooms. The Greta family consists of a chair and small armchair in solid oak wood. Also available in the removable covers' version.



GRETA

695/P
poltroncina | small armchair

695
sedia | chair



DESIGN
ALEXANDER LORENZ

sgabello up&down | up&down stool

Bon Ton

Dal look contemporaneo, lo sgabello Bon Ton si inserisce in ogni contesto, dalla casa ad ambientazioni contract, dai bar ai ristoranti, grazie alla semplicità del suo disegno. Dotato di pratico poggiatesta, presenta inoltre un sistema a gas che permette di regolare l'altezza.

With a contemporary look, the Bon Ton stool fits into any context, from the home to contract settings, from bars to restaurants, thanks to the simplicity of its design. Equipped with a practical footrest, it also has a gas lift system that allows you to adjust its height.



BON TON | 770/A-GAS
sgabello up&down | up&down stool

DESIGN
ALEXANDER LORENZ

tavoli allungabili | extendable tables
madia | sideboard

Diva

La collezione Diva è composta da tavoli allungabili e mobile contenitore nei quali è vigorosa la presenza del legno di rovere che si stempera nella delicatezza del disegno. Il piedistallo metallico fa del tavolo Diva una sorta di scultura rendendolo protagonista del dining.

A caratterizzare la madia, un gioco di delicate contrapposizioni: la parte superiore del mobile si sviluppa seguendo una linea arrotondata alle estremità facendo da contrappunto alla geometricità creata dall'incrocio delle gambe.

The Diva collection is composed by extendable tables and a storage furniture, characterized by the vigorous presence of oak wood, which tones down in the delicate design. The metal pedestal makes the Diva table a sort of sculpture making it the protagonist of the dining room.

The sideboard is characterized by a play of delicate contrasts: the upper part of the unit develops following a rounded line at the ends, counterpointing the geometry created by the crossing of the legs.



DIVA tavolo allungabile | extendable table

DIVA

775/TC1
tavolo allungabile | extendable table



DIVA

775/TC1
tavolo allungabile | extendable table



DIVA

775/TO2
tavolo allungabile | extendable table



DIVA

775/TO2
tavolo allungabile | extendable table







DESIGN
SERENA CONFALONIERI

specchio a parete | wall mirror

Stilla

Stilla è uno specchio a parete che si ispira alla forma dei pendenti in cristallo, riprendendo il tradizionale taglio a goccia delle pietre preziose. Un complemento che si contraddistingue nella scelta di ricercate finiture: il profilo dello specchio e l'elemento di fissaggio circolare sono rivestiti in pelle nei colori di collezione, mentre i due tondini in metallo sono in ottone brunito.

Stilla is a wall mirror that gets inspiration from the form of the crystal pendant's shape, echoing the traditional drop cut of precious stones. A distinctive furniture accessory that selects sophisticated finishes: the profile of the mirror and the circular attachment part are covered in leather in the colors as per collection, while the two metal rods are in bronzed brass.



STILLA specchio a parete | wall mirror - VIGO lounge | lounge chair - ROPU tavolino | coffee table - WOOD_Y consolle | console



STILLA / 890/S
specchio a parete | wall mirror



STILLA specchio a parete | wall mirror - LOOM divano componibile | modular sofa - ROPU tavolini | coffee tables

DESIGN
ENRICO FRANZOLINI E
CRISTIAN MALISAN

sedia | chair
poltroncine | small armchairs
sgabello alto | barstool

Miura

Caratterizzata da linee sinuose e morbide, la famiglia Miura si declina in sedia, poltroncine e sgabello. La profonda cura sartoriale è evidenziata dalle cuciture a vista del rivestimento che segue la silhouette della seduta.

La poltroncina è disponibile anche nella versione interamente imbottita e, a scelta, il piedino in tre finiture: cromato, ottone brunito o cromo nero.

Characterized by sinuous and soft lines, the Miura family is composed of chair, small armchairs, and stool. The deep tailoring care is highlighted by the visible stitching of the upholstery that follows the silhouette of the seat. The small armchair is also available in the fully upholstered version and, optionally, the foot in three finishes: chrome, bronzed brass, or black chrome.



MIURA

776/W
sedia | chair



316



MIURA

776/PW
poltroncina | small armchair

MIURA

776/P
poltroncina | small armchair



317

MIURA 776/AW
sgabello alto | barstool



DESIGN
ALEXANDER LORENZ

poltroncina | small armchair
poltrona | armchair
pouf | pouf

Venus

Avvolgenti schienali e morbide sedute, in tessuto o pelle, alla quale fanno da contrappunto le gambe in massello di faggio dalla linea squadrata, contraddistinguono la famiglia di sedute Venus composta da poltroncina, poltrona e pouf.

Embracing backrests and soft seats, in fabric or leather; to which the square-shaped solid beech legs counterpoint, distinguish the Venus family of seating consisting of a small armchair, armchair and pouf.



VENUS

757/PB
poltrona | armchair



VENUS / 757/P
poltroncina | small armchair

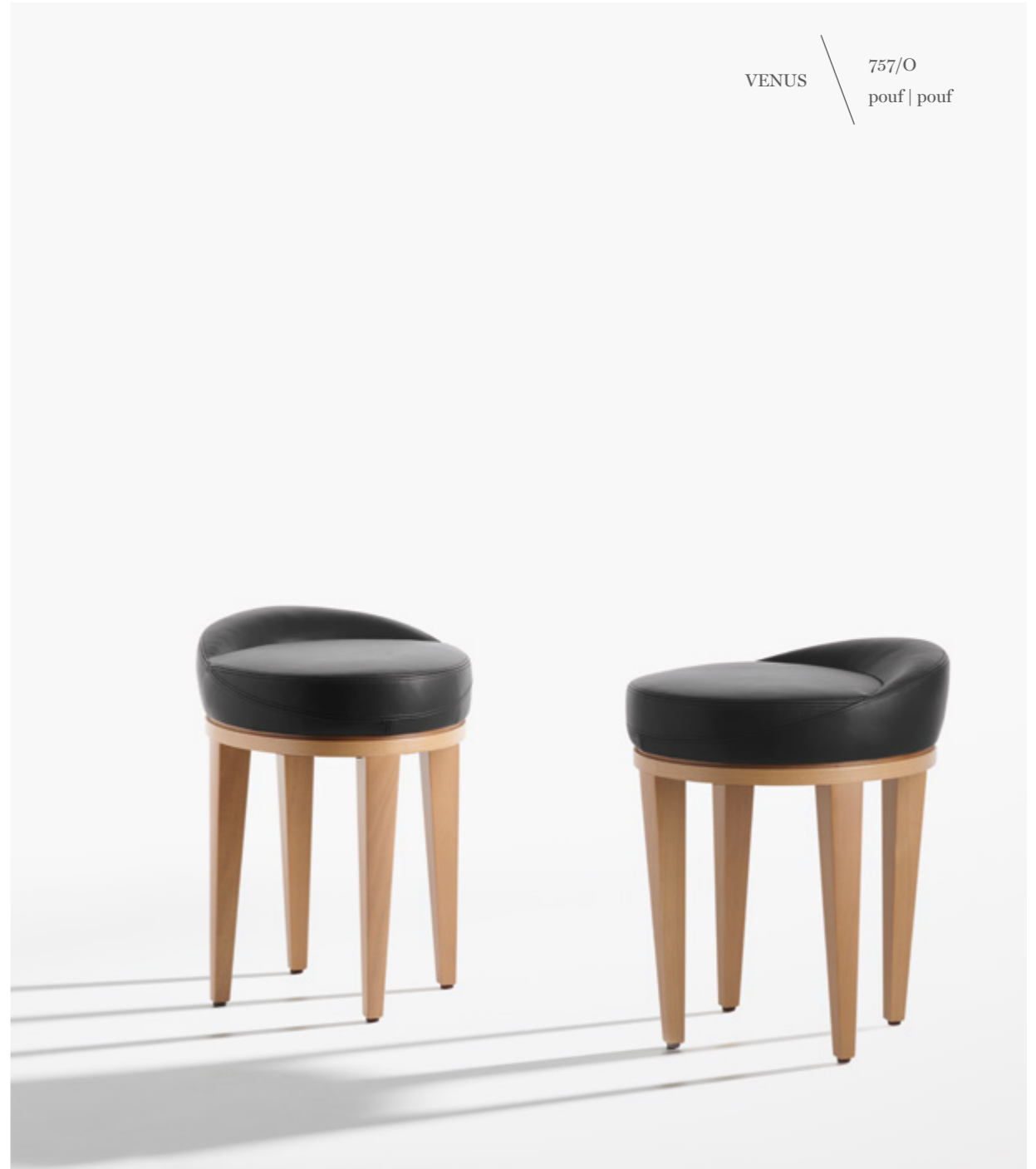

VENUS / 757/O
pouf | pouf

DESIGN
WOLFGANG C.R. MEZGER

sgabello alto | barstool
sgabelli up&down | up&down stools

Jolly

La famiglia di sgabelli Jolly si contraddistingue per la scocca rigida ed ergonomica dello schienale, in tessuto o pelle, dalla curvatura tridimensionale che consente una seduta sostenuta ma all'insegna del confort. Ideali per dare un tocco di carattere al proprio angolo bar così come in un contesto contract.

The Jolly stools' collection is characterized by a rigid, ergonomic backrest shell, made in fabric or leather as per collection, with a three-dimensional curvature that allows a sustained but comfortable seat. Ideal for giving a touch of character to a bar area as well as in a contract context.



JOLLY

751/AHW
sgabello alto | barstool



326

JOLLY

751/AI-GAS
sgabello up&down | up&down stool



JOLLY

751/AII-GAS
sgabello up&down | up&down stool



327

DESIGN
MARCO PIVA

sedia impilabile | stackable chair
poltroncina impilabile | stackable small armchair
poltroncina | small armchair

Slice

Sedia e poltroncina compongono la famiglia di sedute impilabili Slice. Elemento di unicità e distinzione, il dettaglio delle sottili aperture laterali dell'imbottitura in tessuto o pelle che, formando degli occhielli nella parte alta dello schienale, lasciano intravedere la struttura in massello di faggio. Sedute profonde e schienali lievemente inclinati sottolineano l'attenzione al comfort.

A chair and small armchair compose the Slice family of stackable seating. A unique and distinct element is the detail of the slender side openings of the fabric or leather upholstery, that creating eyelets in the upper part of the backrest, allow a glimpse of the solid beech frame. Deep seats and slightly inclined backrests emphasize the attention to comfort.



SLICE

772/PW

poltroncina impilabile | stackable small armchair

772

sedia impilabile | stackable chair



SLICE

772/PI

poltroncina | small armchair

DESIGN
CHIARAMONTE MARIN

sedia | chair
poltrona | armchair
pouf | pouf
tavolino | coffee table

Otta

La collezione Otta composta da sedia, poltrona, pouf e tavolini si distingue per il look retrò e per la caratteristica forma ottagonale del sedile imbottito in tessuto o pelle, accompagnata dal profilo dello schienale e ripresa nel piano dei tavolini proposto in faggio o marmo. Dall'ambito contract a quello domestico, Otta è una proposta trasversale in grado di vivere in ambienti differenti.

The Otta collection consisting of chair, armchair, pouf, and coffee tables stands out for its retro look and for the characteristic octagonal shape of the upholstered seat in fabric or leather, accompanied by the profile of the backrest and reproduced also in the top of the coffee tables proposed in beech or marble. From contract to domestic ambiances, Otta is a transversal proposal able to live in different environments.



OTTA poltrona | armchair, pouf | pouf, tavolino | coffee table

OTTA

940/L
poltrona | armchair



OTTA

940/O
pouf | pouf

OTTA

940/T
tavolino | coffee table



OTTA

940
sedia | chair



DESIGN
POTOCO D&D

tavolini | coffee tables

Little T

La rigorosa struttura in metallo gofrato anima il disegno dei tavolini Little T. Proposti in tre dimensioni e altezze diverse, i tavolini sono ideali come piano d'appoggio fianco e fronte divano o a creare differenti composizioni. Con piano in grès porcellanato o in una preziosa gamma di marmi, sono pensati per l'utilizzo sia in ambiti domestici che contract. I tavolini, inoltre, sono disponibili nella versione per outdoor.

The rigorous embossed metal structure animates the design of the Little T coffee tables. Available in three different sizes and heights, these coffee tables are ideal as a side or front sofa table, creating different compositions. With laminated porcelain or marble top, they are designed for both domestic and contract ambiances. They are also available in the outdoor version.





LITTLE T

878/TQ-100
tavolino | coffee table

878/TR
tavolino | coffee table

878/TQ-50
tavolino | coffee table



LITTLE T tavolino | coffee table - VIGO lounge | lounge chair - LOOM divano | sofa

Technical
Sheet

04.

ANFORA

Design Alexander Lorenz
 \ pag. 232

Tavolo con piano circolare in due dimensioni con:
 - Base centrale in marmo e piano in vetro bronzo temperato o in noce Canaletto.
 - Base centrale in quarzo resinato antracite o Light Grey con piano vetro bronzo temperato, marmo Bianco Carrara, marmo Grigio Carnico.
 Accessorio abbinato: piatto centrale girevole lazy susan.
 Finiture di collezione.

Round table available in two dimensions with:
 - Central marble base with bronzed tempered glass or Canaletto walnut top.
 - Central resinated quartz base in the Anthracite or Light grey finishes, with the top in bronzed tempered glass, white Carrara marble, Grigio Carnico marble.
 Matching accessory: lazy susan central rotating plate.
 Finishes as per collection.

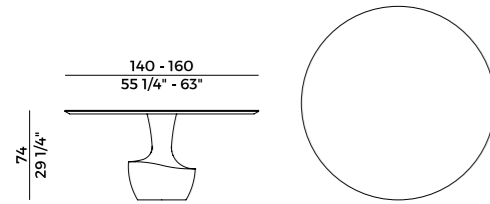

879/T
 tavolo \ table

ARIAL

Design Gabriele e Oscar Buratti
 \ pag. 244

Famiglia di consolle e librerie.
 Librerie autoportanti, in due altezze, con 6 o 3 ripiani in frassino o noce Canaletto e struttura in metallo disponibile in due finiture:
 - Struttura in ottone brunito con piedini in antracite goffrato.
 - Struttura in antracite goffrato con piedini in ottone brunito.
 Consolle con due cassetti. Parte superiore e ripiano inferiore in frassino o noce Canaletto impiallacciato e bordi superiori in legno massello.
 Struttura in metallo disponibile in due finiture:
 - Struttura in ottone brunito con piedini in antracite goffrato.
 - Struttura in antracite goffrato con piedini in ottone brunito.
 Top disponibili in marmo, vetro retro verniciato nero temperato, frassino e noce Canaletto.
 Disponibili cassetti opzionali.

Family of bookshelves and console.
 Freestanding bookshelves, in two heights, with 6 or 3 ash wood or Canaletto Walnut shelves and metal structure available in two finishes:
 - Bronzed brass structure with embossed anthracite metal feet.
 - Embossed anthracite metal structure with bronzed brass feet.
 Console with two drawers. Upper part and lower shelf in veneered ash wood or Canaletto walnut and upper edges in solid wood. Metal structure available in two finishes:
 - Bronzed brass structure with embossed anthracite metal feet.
 - Embossed anthracite metal structure with bronzed brass feet.
 Top available in marble, black back painted tempered glass, ash wood and Canaletto walnut.
 Optional drawers available.

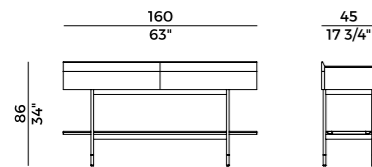

870/CS
 consolle \ console

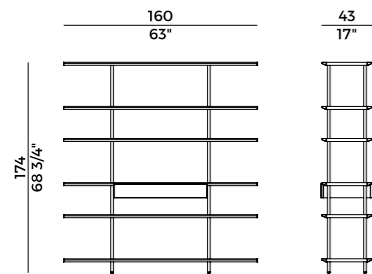

870/ML
 libreria autoportante \ freestanding bookcase

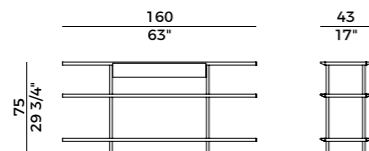

870/MS
 libreria autoportante \ freestanding bookcase

AURA

Design Mauro Lipparini
 \ pag. 110

Tavolo allungabile con struttura in rovere e dettagli in alluminio satinato. Piano in legno rovere. Disponibile in versione circolare o ovale con allungata centrale. Finiture di collezione.

Extendable table with oak structure and satin aluminum details. Oak wooden top. Available in circular or oval version with central extension. Finishes as per collection.

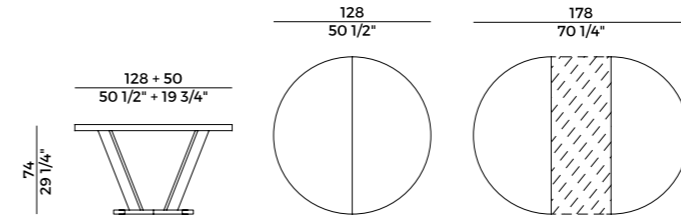

830/TC1
 tavolo allungabile \ extendable table

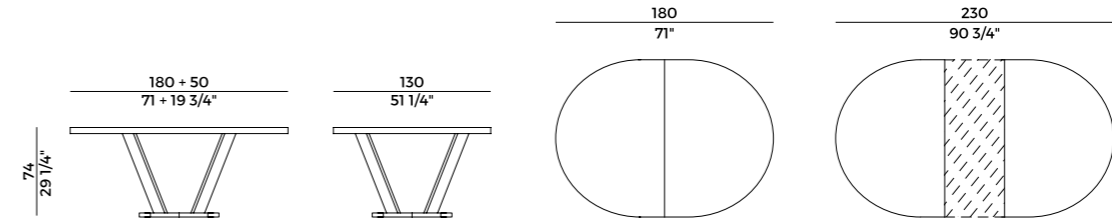

830/TO1
 tavolo allungabile \ extendable table

AVANT

Design Gabriele e Oscar Buratti
 \ pag. 218

Famiglia di contenitori. Credenza e madia con struttura in frassino o noce Canaletto.
 Madia a 3 e a 4 ante, con gambe in due altezze in ottone brunito.
 Piano superiore in marmo, frassino, noce Canaletto o vetro retro verniciato nero temperato. All'interno ripiani in vetro nero temperato e, su richiesta, cassetti opzionali.

Family of storage furniture. Cabinet and sideboards with ash wood or Canaletto walnut structure.
 Sideboard with 3 or 4 doors, with legs in two heights in bronzed brass.
 Upper top in marble, ash wood, Canaletto walnut or black back painted tempered glass. Inside black tempered glass shelves and, on request, optional drawers.

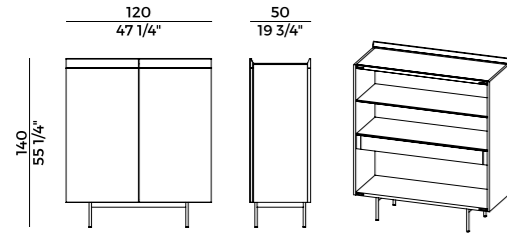

884/MA
credenza \ cabinet

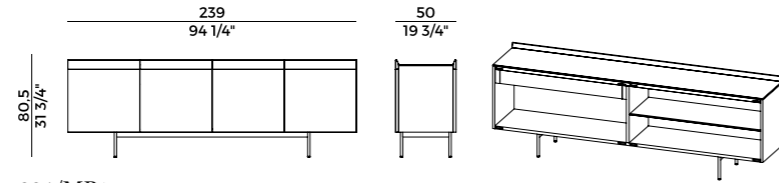

884/MB1
madia \ sideboard

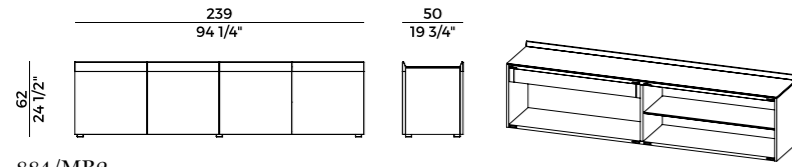

884/MB2
madia \ sideboard

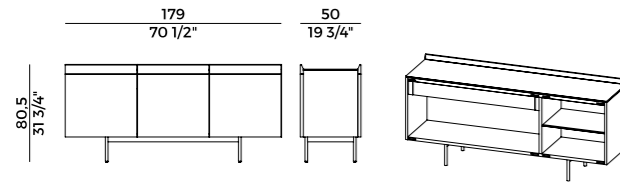

884/MB1-180
madia \ sideboard

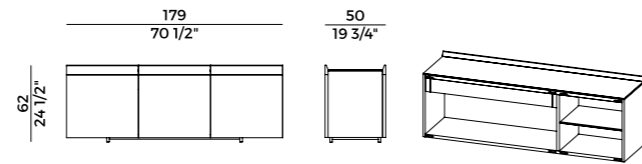

884/MB2-180
madia \ sideboard

BLOSSOM

Design Bernhardt & Vella
 \ pag. 130

Collezione di arredi composta da sedute e tavolo allungabile.
 Sedia, poltroncina, divano e poltrona con base in massello di frassino e seduta e schienale imbottiti in poliuretano espanso ignifugo.
 Sgabello con seduta e schienale imbottiti in poliuretano espanso ignifugo. Proposto in due versioni:
 - Base a quattro gambe in massello di frassino.
 - Gamba centrale girevole e base in metallo tonda o quadrata, con sistema di regolazione a gas.
 Tavolo allungabile con struttura e piano in frassino. Allunga in testa.
 Finiture e rivestimenti di collezione.

Furniture collection consisting of seats and extendable table.
 Chair, small armchair, sofa, and armchair with base in solid ash wood, seat and backrest padded in fire-retardant polyurethane foam.
 Stool with seat and backrest padded in fire retardant polyurethane foam. Proposed in two versions:
 - With four legs base in solid ash wood.
 - With central swivel leg and round or square metal base, with gas lift system.
 Extendable table with structure and top in ash wood. Overhead extension.
 Finishes and coverings as per collection.

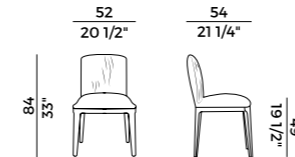

840
sedia \ chair

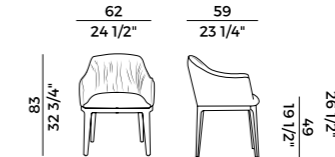

840/P
poltroncina \ small armchair

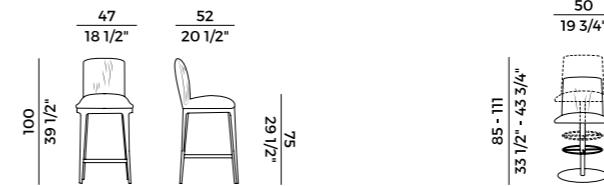

840/A
sgabello alto \ barstool

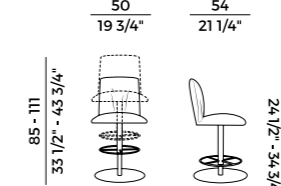

840/A-GAS
sgabello up&down \ up&down stool

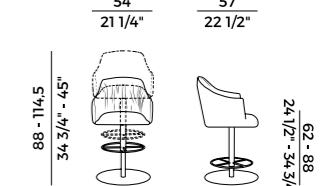

840/AP-GAS
sgabello up&down \ up&down stool

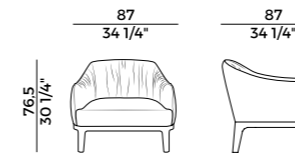

840/PL
poltrona \ armchair

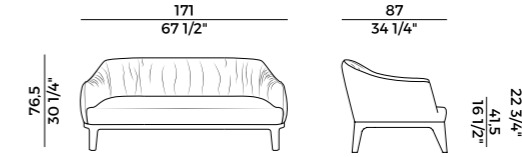

840/D
divano \ sofa

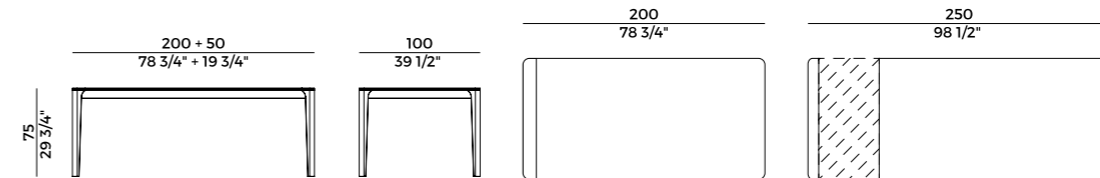

840/TR1
tavolo allungabile \ extendable table

BON BON

Design Alexander Lorenz
 \ pag. 056

Famiglia di tavoli e tavolino con base in metallo verniciato così composta:

- Tavoli con base tonda disponibili con piano circolare o ovale in noce Canaletto, marmo o vetro trasparente temperato.
 - Tavoli con base rettangolare disponibile con piano circolare, ovoide e rettangolare in noce Canaletto, marmo o vetro trasparente temperato.
 - Tavolino con base piccola tonda e piano circolare in noce Canaletto, marmo vetro trasparente temperato.
- Finiture di collezione.

Family of tables and coffee table with lacquered metal base composed as follows:

- Tables with round base available with circular or oval top in Canaletto walnut, marble, or transparent tempered glass.
 - Tables with rectangular base available with circular, oval, and rectangular top in Canaletto walnut, marble, or transparent tempered glass.
 - Coffee table with small round base and circular top in Canaletto walnut, marble, or transparent tempered glass.
- Finishes as per collection.

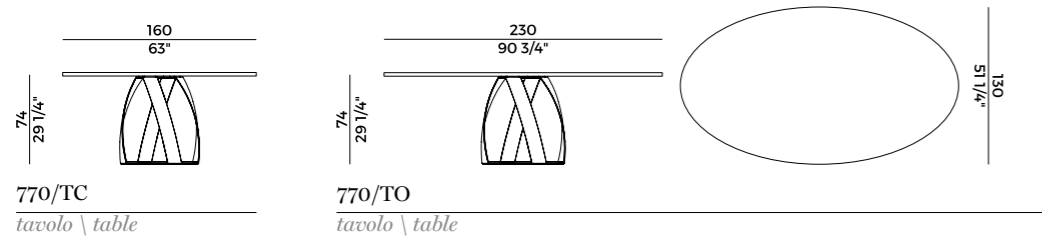

770/TC
 tavolo \ table

770/TO
 tavolo \ table

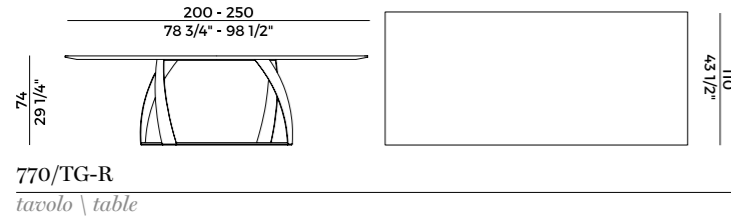

770/TG-R
 tavolo \ table

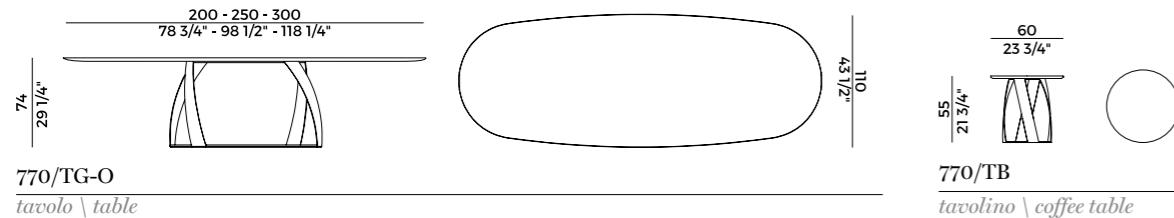

770/TG-O
 tavolo \ table

770/TB
 tavolino \ coffee table

BON TON

Design Alexander Lorenz
 \ pag. 300

Sgabello con gamba centrale girevole in metallo tonda o quadrata, con sistema di regolazione a gas. Seduta in faggio con imbottitura in poliuretano espanso ignifugo. Finiture e rivestimenti di collezione.

Stool with round or square metal swivel central base, with gas lift system. Wooden beech seat padded in fire retardant polyurethane foam. Materials and coverings as per collection.

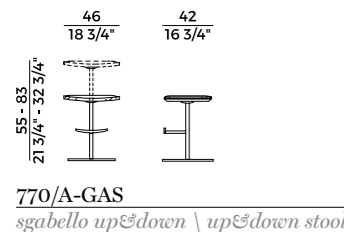

770/A-GAS
 sgabello up&down \ up&down stool

CANDY

Design Bernhardt & Vella
 \ pag. 228

Famiglia di sedute con telaio e gambe in massello di frassino. Seduta e schienale imbottiti in poliuretano espanso ignifugo. Finiture e rivestimenti di collezione.

Family of seats with frame and legs in solid ash wood. Seat and backrest padded in fire retardant polyurethane foam. Materials and coverings as per collection.

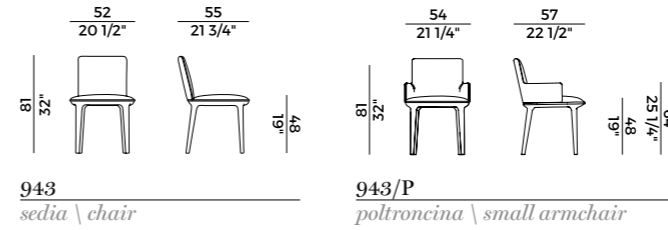

943
 sedia \ chair

943/P
 poltroncina \ small armchair

CONCHA

Design Stephan Veit
 \ pag. 198

Sedia e poltroncina con seduta e schienale imbottiti in poliuretano espanso ignifugo. Gambe in massello di rovere. Finiture e rivestimenti di collezione.

Chair and small armchair with seat and backrest padded in fire retardant polyurethane foam. Legs in solid oak wood. Materials and coverings as per collection.

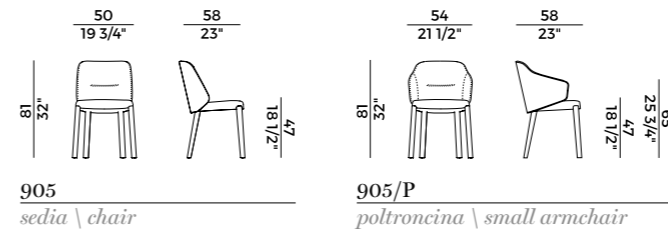

905
 sedia \ chair

905/P
 poltroncina \ small armchair

COULISSE

Design Radice Orlandini
 \ pag. 106

Poltroncina con gambe in massello di faggio. Seduta e schienale imbottiti in poliuretano espanso ignifugo, cinghia decorativa in tessuti da collezione. Finiture e rivestimenti di collezione.

Small armchair with legs in solid beech wood. Upholstered seat and backrest padded in fire retardant polyurethane foam, decorative belt with coverings as per collection. Materials and coverings as per collection.

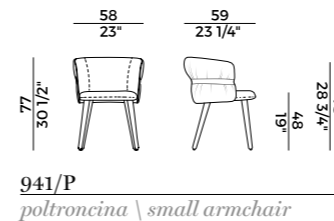

941/P
 poltroncina \ small armchair

CUT

Design Stephan Veit
 \ pag. 260

Bergère in due versioni:

- Fissa con base in alluminio verniciato nero gofrato e con pouf con base in alluminio verniciato nero gofrato.

- Girevole con seduta reclinabile, con blocco in 5 posizioni, e base a quattro razze in alluminio verniciato nero gofrato. Pouf con base a quattro razze in alluminio verniciato nero gofrato.

Seduta e pouf imbottiti in poliuretano espanso ignifugo. Poggiatesta a due regolazioni. Rivestimenti di collezione.

Bergère in two versions:

- Fixed with embossed black painted aluminum base and pouf with base in embossed black painted aluminum.

- Swivel with a reclining seat, with a block in 5 positions, and embossed black painted aluminum four-star base. Pouf with four-star base in embossed black painted aluminum.

Seat and pouf padded in fire retardant polyurethane foam. Headrest with two settings. Coverings as per collection.

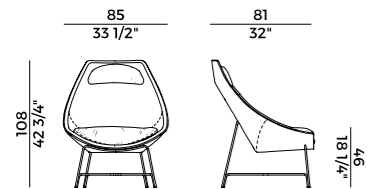

910/PL
 bergère \ bergère

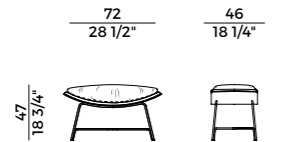

910/PP
 pouf \ pouf

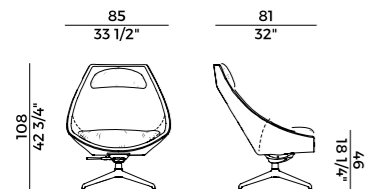

910/PLG
 bergère girevole e reclinabile \ swivel and reclining bergère

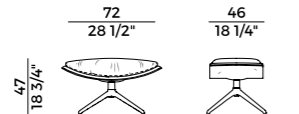

910/PPG
 pouf \ pouf

348

DANCE

Design Alexander Lorenz
 \ pag. 196

Pouf sagomato imbottito in poliuretano espanso ignifugo. Su richiesta, disponibile anche in multi-tessuto. Rivestimenti di collezione.

Shaped pouf padded in fire retardant polyurethane foam. On request available also in multi-fabric. Coverings as per collection.

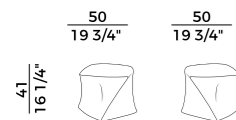

792/O
 pouf \ pouf

DIVA

Design Alexander Lorenz
 \ pag. 302

Collezione di arredi così composta:

- Tavolo allungabile a base centrale con struttura in rovere e metallo.

Disponibile in versione circolare con allunga centrale.

- Tavolo allungabile a base centrale con struttura in rovere e metallo.

Disponibile in versione ellittica con doppia allunga centrale.

- Madia con due ante laterali curvate e sei cassetti centrali con sistema di apertura push&pull. Struttura in rovere. Basamento in massello di rovere.

Finiture di collezione.

Collection of furnishings composed as follows:

- Extendable table with central base with structure in oak and metal.

Available in circular version with central extension.

- Extendable table with central base with structure in oak and metal.

Available in elliptical version with double central extension.

- Sideboard with two curved side doors and six central drawers with push & pull opening system. Structure in oak. Base in solid oak wood.

Finishes as per collection

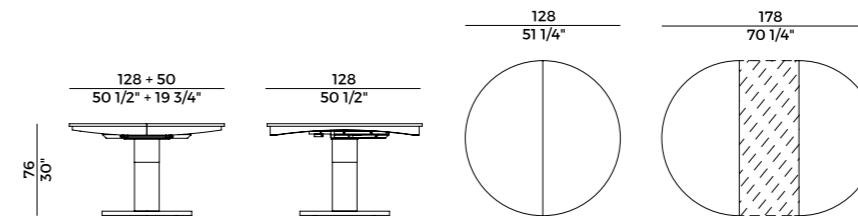

775/TC1
 tavolo allungabile \ extendable table

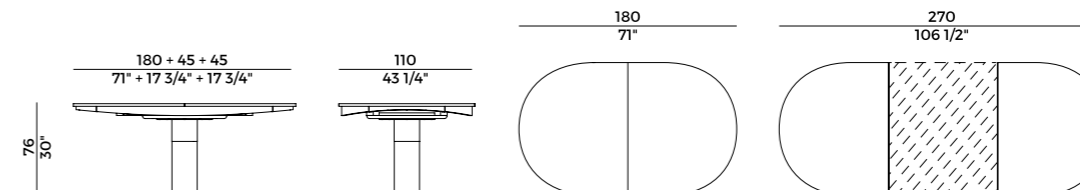

775/TO2
 tavolo allungabile \ extendable table

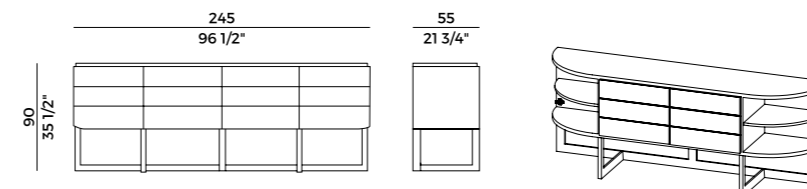

775/M
 madia \ sideboard

349

ELODIE

Design Chiara Andreotti
 \ pag. 274

Divano con struttura in tubo di metallo verniciato gofrato antracite, bianco o Aval. Imbottito in poliuretano espanso ignifugo.

Cuscini dello schienale sfoderabili. Cuscini laterali su richiesta.

Finiture e rivestimenti di collezione.

Elodie è disponibile anche nella versione outdoor.

Sofa with structure in embossed anthracite, white or Aval metal tube. Padded in fire retardant polyurethane foam.

Back cushions with removable covers. Side cushions on request.

Materials and coverings as per collection.

Elodie is available also in the outdoor version.



908/D
 divano \ sofa

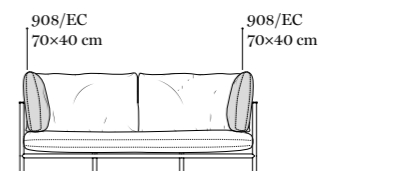

908/EC
 cuscini laterali \ side cushions

GRACE

Design Mauro Lipparini
 \ pag. 094

Collezione di arredi composta da sedute e tavoli con struttura in massello di frassino spazzolato.
 - Sedia, poltroncina e poltroncina pozzetto con seduta imbottita in poliuretano espanso ignifugo e schienale in canna.
 - Divano e poltrona con schienale in canna. Cuscini di seduta e schienale con imbottitura in poliuretano espanso ignifugo.
 - Tavolo allungabile in frassino spazzolato e con anello di protezione in metallo rutenio. Disponibile in versione circolare con allunga centrale.
 - Tavolo allungabile in frassino spazzolato e con anello di protezione in metallo rutenio. Disponibile in versione ovale con allunga centrale.
 Materiali e rivestimenti a collezione.

Collection composed of seats and tables with structure in solid brushed ash wood.
 - Chair, small armchair and tub chair with seat padded in fire retardant polyurethane foam and cane backrest.
 - Sofa and armchair with cane backrest. Seat and backrest cushions padded in fire retardant polyurethane foam.
 - Extendable table in solid brushed ash wood with protection ring in ruthenium metal. Available in the round version with central extension.
 - Extendable table in solid brushed ash wood with protection ring in ruthenium metal. Available in the oval version with central extension.
 Materials and coverings as per collection.

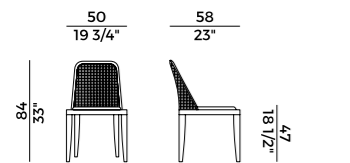

834
 sedia \ chair

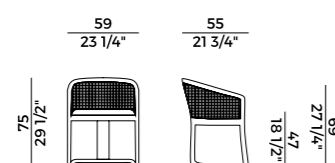

834/PMC
 poltroncina pozzetto \ tub chair

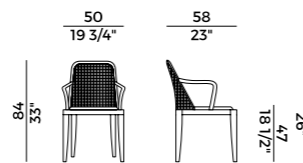

834/P
 poltroncina \ small armchair

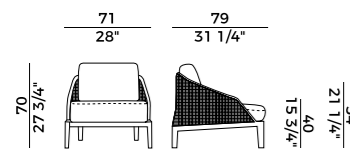

834/PB
 poltrona \ armchair

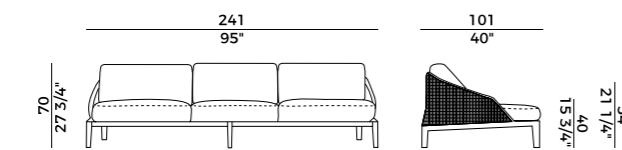

834/D
 divano \ sofa

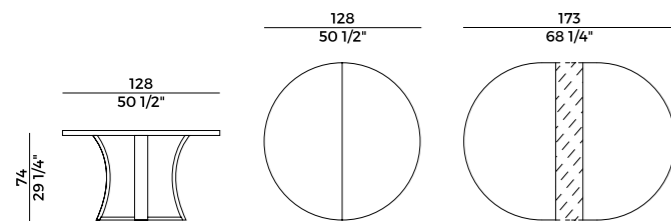

834/TC1
 tavolo allungabile \ extendable table

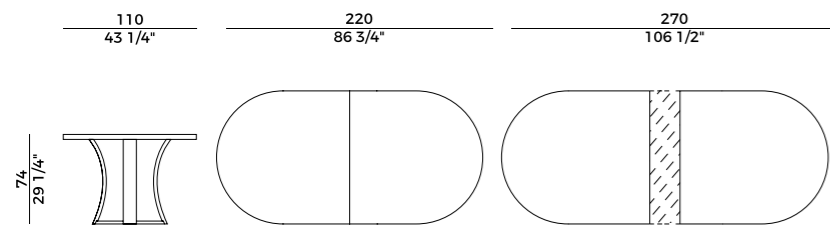

834/TO1
 tavolo allungabile \ extendable table

GRETA

Design Enrico Franzolini
 \ pag. 296

Sedia e poltroncina in massello di rovere, seduta e schienale imbottiti in poliuretano espanso ignifugo, disponibili anche in versione sfoderabile. Finiture e rivestimenti di collezione.

Chair and small armchair in solid oak wood, seat and backrest padded in fire retardant polyurethane foam, available also in the removable covers' version. Materials and coverings as per collection.

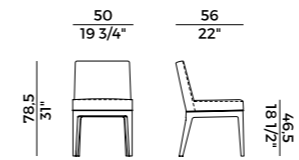

695 - 695/SF
 sedia \ chair

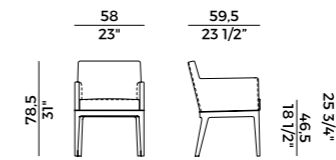

695/P - 695/PSF
 poltroncina \ small armchair

HERM

Design Gianluigi Landoni
 \ pag. 180

Famiglia di pouf imbottiti in poliuretano espanso ignifugo. Disponibili in tre misure. Fascia e rivestimenti a collezione.

Family of upholstered poufs padded in fire retardant polyurethane foam. Available in three sizes. Belt and coverings as per collection.

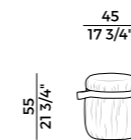

925/O45
 pouf \ pouf

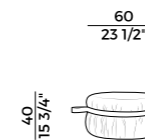

925/O60
 pouf \ pouf

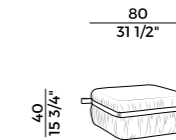

925/O80
 pouf \ pouf

HISHI

Design Chiara Andreatti
 \ pag. 184

Collezione di tavolini così composta:
 - Piano circolare, base in ceramica, altezza 47 cm o 55 cm, con finitura lucida color pesca o grigio sabbia e borchia alla base del piano con finitura ottone brunito. Piano in vetro bronzo temperato o noce Canaletto.
 - Piano quadrato, base in ceramica, altezza 47cm o 55 cm, con finitura lucida color pesca o grigio sabbia e borchia alla base del piano con finitura ottone brunito. Piano in vetro bronzo temperato o noce Canaletto.
 Disponibili anche nella versione outdoor.

Collection of coffee tables as follows:
 - Round top, ceramic base, height 47 cm or 55 cm, in peach or sand grey glossy finish with stud at the base of the top with bronzed brass finish. Bronzed tempered glass or Canaletto walnut top.
 - Square top, ceramic base, height 47 cm or 55 cm, in peach or sand grey glossy finish with stud at the base of the top with bronzed brass finish. Bronzed tempered glass or Canaletto walnut top.
 Available also in the outdoor version.

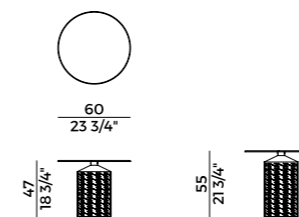

871/TBC
 tavolino \ coffee table

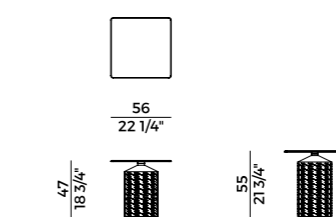

871/TBQ
 tavolino \ coffee table

JOLLY

Design Wolfgang C.R. Mezger
 \ pag. 324

Sgabelli disponibili nelle seguenti versioni:

- Sgabello alto con quattro gambe in massello di rovere, poggiatesta in Inox lucido e seduta e schienale imbottiti in poliuretano espanso ignifugo.
 - Sgabello con gamba centrale girevole con base in metallo tonda o quadrata, con sistema di regolazione a gas. Seduta e schienale imbottiti in poliuretano espanso ignifugo. Lo schienale è disponibile in doppia versione: tutto imbottito oppure con solo schienale esterno rivestito in legno rovere.
- Finiture e rivestimenti di collezione.

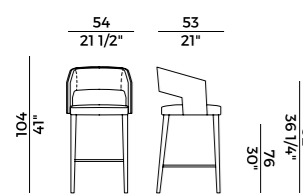

751/AIIW
 sgabello alto \ barstool

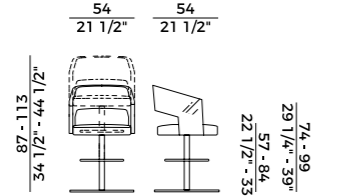

751/AI-GAS
 sgabello up&down \ up&down stool

Stools available in the following versions:

- Barstool with four legs in solid oak wood, footrest in stainless steel and upholstered seat and backrest padded in fire retardant polyurethane foam.
 - Stool with round or square metal swivel central base with gas lift system. Upholstered seat and backrest padded in fire retardant polyurethane foam. The backrest is available in two versions: fully upholstered or with only the external panel covered in oak wood.
- Materials and coverings as per collection.

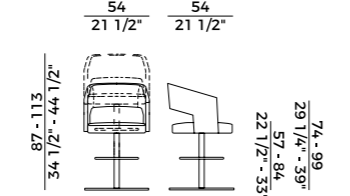

751/AII-GAS
 sgabello up&down \ up&down stool

KEEL

Design M+V
 \ pag. 068

Sedia e poltroncina con struttura in tondino di metallo verniciato goffrato antracite o Aval, schienale in massello di frassino e seduta sfoderabile imbottita in poliuretano espanso ignifugo. Disponibili anche nella versione outdoor. Finiture e rivestimenti di collezione.

Chair and small armchair with Anthracite or Aval embossed metal rod structure, backrest in solid ash wood and seat with removable coverings padded in fire retardant polyurethane foam. Available also in the outdoor version. Materials and coverings as per collection.

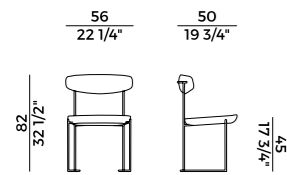

922
 sedia \ chair

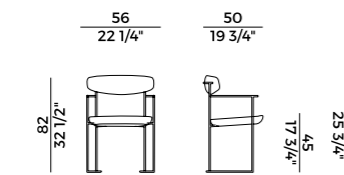

922/P
 poltroncina \ small armchair

LARS

Design Gabriele e Oscar Buratti
 \ pag. 084

Sedia e poltroncina stampate in poliuretano espanso ignifugo ed interamente imbottite. Cuciture in contrasto disponibili su richiesta. Rivestimenti di collezione.

Chair and small armchair padded in fire-retardant polyurethane foam and fully upholstered. Contrasting stitching available on request. Coverings as per collection.

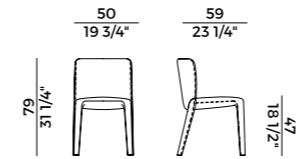

902
 sedia \ chair

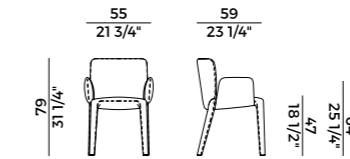

902/P
 poltroncina \ small armchair

LÉNA

Design Gabriele e Oscar Buratti
 \ pag. 124

Collezione di sedute così composta:

- Sedia e poltroncina in massello di frassino con seduta e schienale imbottiti in poliuretano espanso ignifugo.
 - Poltrona in massello di frassino con seduta e schienale imbottiti in poliuretano espanso ignifugo.
 - Poltrona imbottita in poliuretano espanso ignifugo con base centrale girevole con meccanismo di ritorno a quattro razze in alluminio verniciato nero o antracite goffrato.
- Disponibile versione bimatetica. Rivestimenti di collezione.

Seating family composed as follows:

- Chair and small armchair in solid ash wood with seat and backrest padded in fire retardant polyurethane foam.
 - Armchair in solid ash wood with seat and backrest padded in fire retardant polyurethane foam.
 - Armchair padded in fire retardant polyurethane foam with central swivel base with four-star return mechanism in embossed black or anthracite painted aluminum.
- Available in the bi-material version. Coverings as per collection.

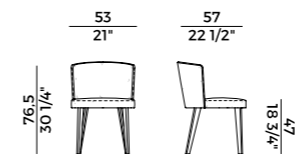

903
 sedia \ chair

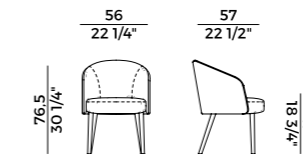

903/P
 poltroncina \ small armchair

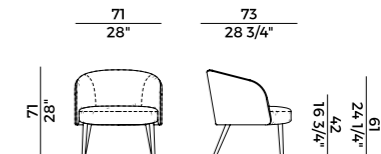

903/PL
 poltrona \ armchair

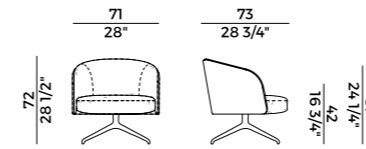

903/PLG
 poltrona girevole \ swivel armchair

LINUS

Design Stephan Veit
 \ pag. 264

Collezione di arredi composta da tavolo, sgabello e scrittoio.
 - Tavolo circolare e allungabile proposto in due misure con struttura e piano in rovere. Allunga centrale.
 - Scrittoio con struttura in massello di faggio con piano e cassetti rivestiti in cuoio.
 - Sgabello alto con quattro gambe in massello di faggio e imbottito in poliuretano espanso ignifugo.
 Finiture e rivestimenti di collezione.

Collection composed of table, stool and writing desk.
 - Extendable round table available in two sizes with solid oak wood structure and top. Central extension.
 - Writing desk with solid beech wood structure and hide-leather-covered top and drawers.
 - Barstool with four legs in solid beech wood, padded in fire retardant polyurethane foam.
 Finishes and coverings as per collection.

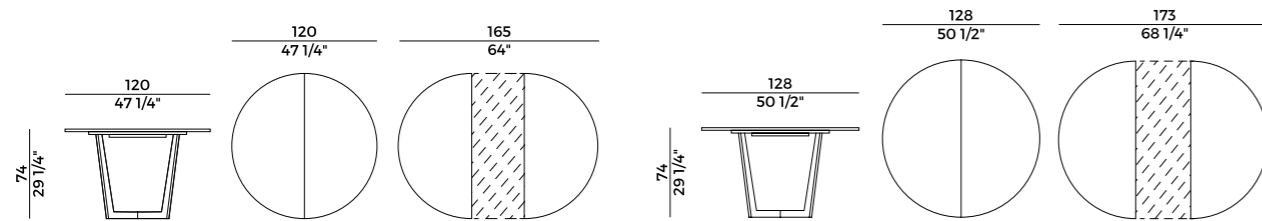

730/TC1
 tavolo allungabile \ extendable table

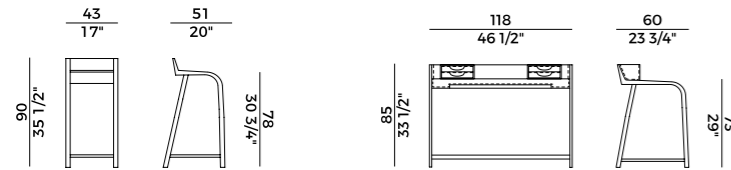

730/AI
 sgabello alto \ barstool

730/SCR
 scrittoio \ writing desk

LITTLE T

Design Potocco D&D
 \ pag. 336

Famiglia di tavolini con struttura in ottone brunito o metallo verniciato antracite goffrato.
 Piano quadrato o rettangolare in grès porcellanato o marmo.
 Finiture di collezione.
 Collezione disponibile anche nella versione outdoor.

Family of coffee tables with bronzed brass or anthracite embossed lacquered metal frame.
 Circular or rectangular top in laminated porcelain or marble.
 Finishes as per collection.
 Collection available also in the outdoor version.

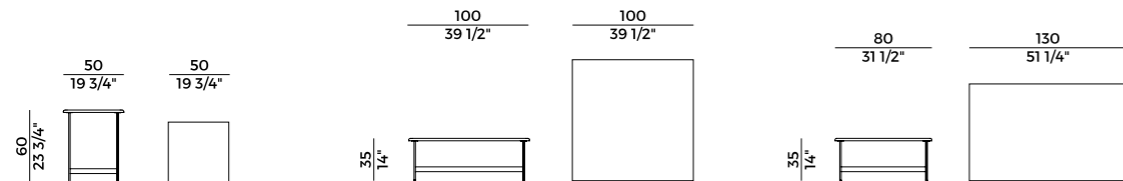

878/TQ-50
 tavolino \ coffee table

878/TQ-100
 tavolino \ coffee table

878/TR
 tavolino \ coffee table

LOOM

Design David Lopez Quincoes
 \ pag. 156

Collezione di divani componibili, poltrona e daybed.
 Struttura in massello di mogano con inserti in canna. Piedini in ottone brunito o metallo verniciato antracite goffrato. Cuscineria interna in poliuretano espanso ignifugo.
 Cuscini laterali su richiesta. Finiture e rivestimenti di collezione.
 Collezione disponibile anche nella versione outdoor.
 Finiture e rivestimenti di collezione.

Collection of modular sofas, armchair and daybed.
 Solid mahogany wooden frame with cane inserts. Feet in bronzed brass or anthracite embossed lacquered metal. Cushions in fire retardant polyurethane foam padding.
 Side cushions on request. Materials and coverings as per collection.
 Collection available also in the outdoor version.
 Materials and coverings as per collection.

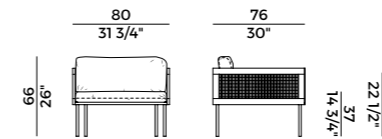

880/PC
 poltrona \ armchair

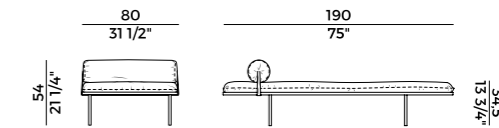

880/DB
 daybed \ daybed

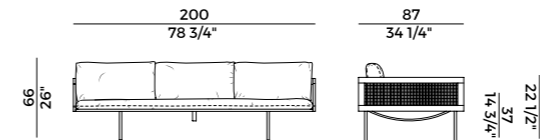

880/DC-200
 divano \ sofa

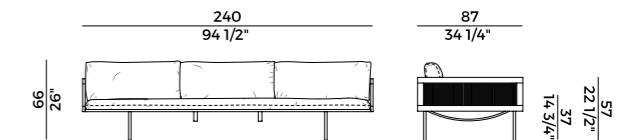

880/DC
 divano \ sofa

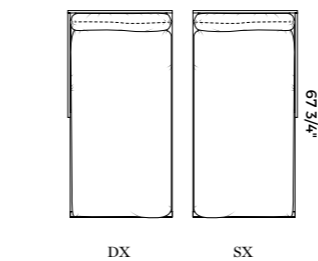
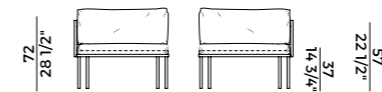

880/DCL
 modulo chaise longue destro e sinistro \ right and left chaise longue unit

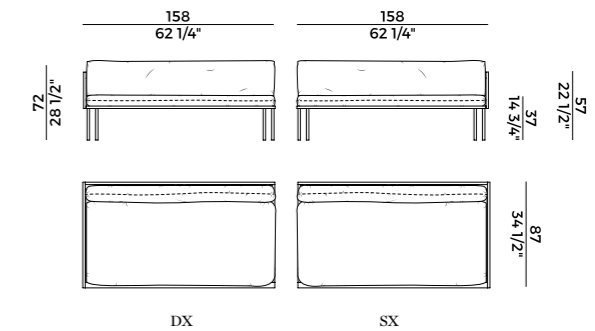

880/DCM
 modulo laterale destro e sinistro \ right and left side unit

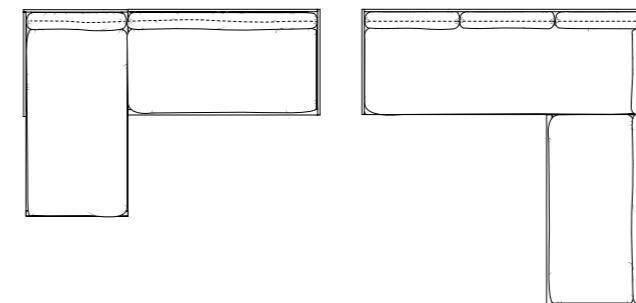

880/DCL + 880/DCM
 divano componibile \ modular sofa

880/DC + 880/DCM

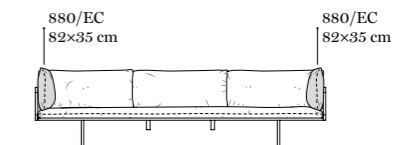

880/EC
 cuscini laterali \ side cushions

LYZ

Design Mario Ferrarini
 \ pag. 146

Sedia e poltroncina con seduta e schienale imbottiti in poliuretano espanso ignifugo. In due versioni:

- Con dettaglio in frassino o noce Canaletto.
- Seduta tutta imbottita.

Disponibili con le seguenti basi:

- Base fissa in frassino o noce Canaletto.
 - Base girevole quattro razze in metallo verniciato Aval o nero goffrato con meccanismo di ritorno.
 - Base centrale a cono girevole in metallo verniciato antracite goffrato o nero goffrato con meccanismo di ritorno.
 - Base a slitta in metallo verniciato antracite goffrato o nero goffrato.
 - Base a cantilever in metallo verniciato antracite goffrato o nero goffrato.
- Finiture e rivestimenti di collezione.

Chair and small armchair with seat and backrest padded in fire retardant polyurethane foam. Available in two versions:

- With solid Ash wood or Canaletto Walnut detail.
 - Fully upholstered seat.
- Available with different bases:
- Fixed version with base in solid ash wood or Canaletto walnut.
 - Four-star swivel base in embossed painted metal, finishes Aval or black with return mechanism.
 - Central cone base in anthracite or black embossed painted metal with return mechanism.
 - Sled legs base in anthracite or black embossed painted metal.
 - Cantilever base in anthracite or black embossed painted metal.
- Finishes and coverings as per collection.

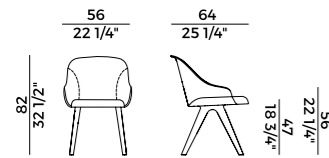

918
 sedia \ chair

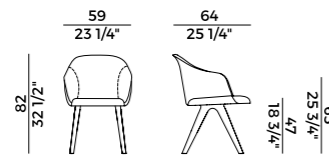

918/P
 poltroncina \ small armchair

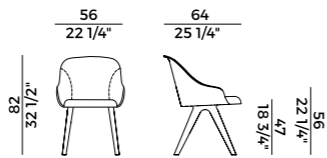

918/I
 sedia \ chair

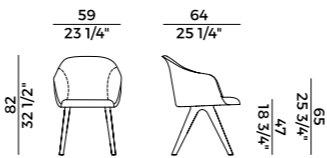

918/PI
 poltroncina \ small armchair

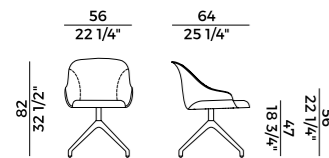

918/G
 sedia girevole \ swivel chair

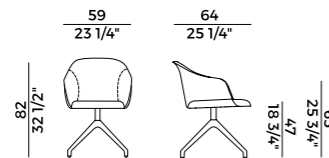

918/PG
 poltroncina girevole \ swivel small armchair

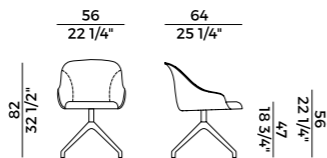

918/GI
 sedia girevole \ swivel chair

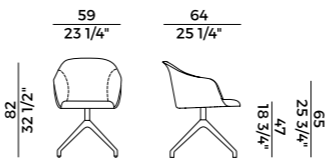

918/PGI
 poltroncina girevole \ swivel small armchair

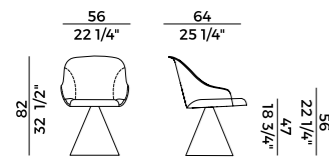

918/GC
 sedia base cono girevole \ cone base swivel chair

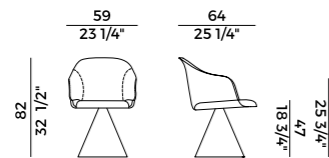

918/PGC
 poltroncina base cono girevole \ cone base swivel small armchair

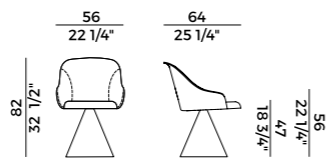

918/GCI
 sedia base cono girevole \ cone base swivel chair

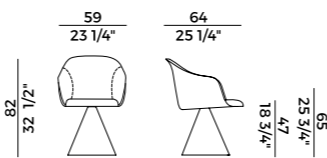

918/PGCI
 poltroncina base cono girevole \ cone base swivel small armchair

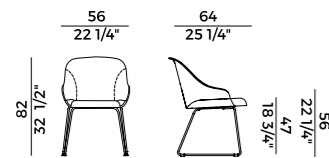

918/SL
 sedia base slitta \ sled base chair

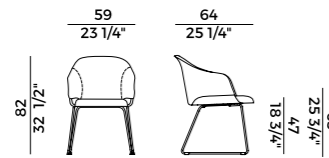

918/PSL
 poltroncina base slitta \ sled base small armchair

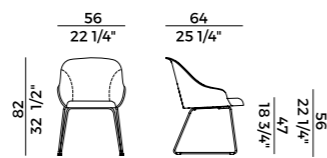

918/SLI
 sedia base slitta \ sled base chair

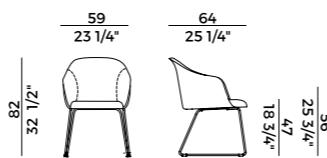

918/PSLI
 poltroncina base slitta \ sled base small armchair

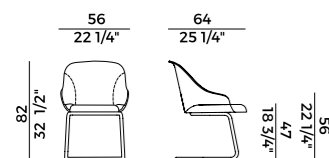

918/U
 sedia base cantilever \ cantilever base chair

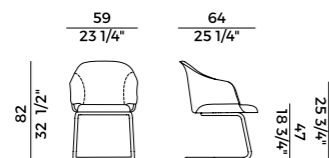

918/PU
 poltroncina base cantilever \ cantilever base small armchair

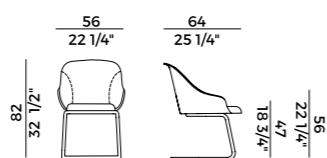

918/UI
 sedia base cantilever \ cantilever base chair

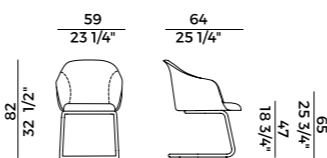

918/PUI
 poltroncina base cantilever \ cantilever base small armchair

MEMORY

Design Rodrigo Torres
 \ pag. 208

Poltroncina con struttura in massello di frassino e seduta e schienale imbottiti in poliuretano espanso ignifugo. Finiture e rivestimenti di collezione.

Small armchair with solid ash wood frame and seat and backrest padded in fire retardant polyurethane foam padding. Materials and coverings as per collection.

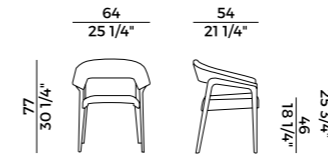

842/P
 poltroncina \ small armchair

MIURA

Design Enrico Franzolini e Cristian Malisan
 \ pag. 314

Famiglia di sedute così composta:

- Sedia e poltroncina imbottite in poliuretano espanso ignifugo con telaio e gambe in massello di faggio. Piedino in metallo in tre finiture: cromato, ottone brunito o cromo nero.
 - Poltroncina interamente imbottita in poliuretano espanso ignifugo con piedino in metallo o interamente imbottito. Piedino in metallo in tre finiture: cromato, ottone brunito o cromo nero.
 - Sgabello imbottito in poliuretano espanso ignifugo con base a quattro gambe in massello di faggio.
- Finiture e rivestimenti di collezione.
 Poltroncina disponibile interamente imbottita. Finiture e rivestimenti di collezione.

Seating family composed as follows:

- Chair and small armchair padded in fire retardant polyurethane foam with frame and legs in solid beech wood. Metal foot in three finishes: chrome, bronzed brass, or black chrome.
 - Fully upholstered small armchair in fire retardant polyurethane foam with metal foot or entirely upholstered. Metal foot in three finishes: chrome, bronzed brass or black chrome.
 - Barstool padded in fire-retardant polyurethane foam with four-legged base in solid beech wood.
- Materials and coverings as per collection.
 Small armchair available in the fully upholstered version. Finishes and coverings as per collection.

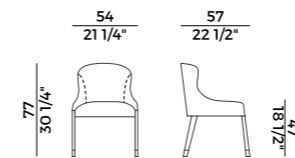

776/W
 sedia \ chair

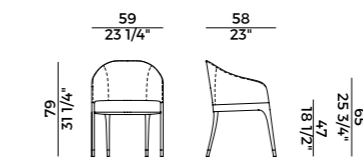

776/PW
 poltroncina \ small armchair

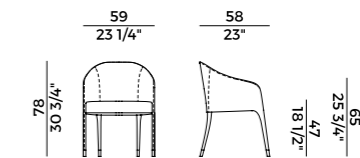

776/P
 poltroncina \ small armchair

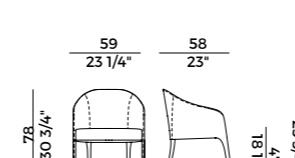

776/PII
 poltroncina \ small armchair

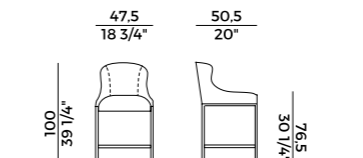

776/AW
 sgabello alto \ barstool

OPUS

Design Bernhardt & Vella
 \ pag. 072

Tavolo con base componibile in massello di frassino o noce Canaletto. Piani in marmo, frassino o noce Canaletto disponibili in versione quadrata, a botte o circolare. Finiture di collezione.

Table with modular base in solid ash wood or Canaletto walnut. Tops in marble, ash wood or Canaletto walnut available in square, barrel or circular versions. Finishes as per collection.

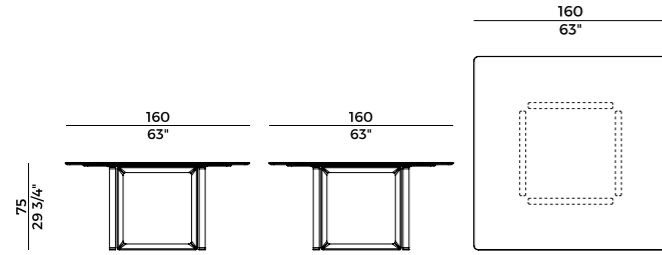

893/TQ
 tavolo base componibile \ modular base table

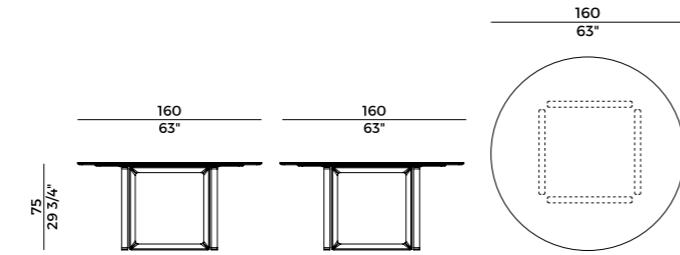

893/TC
 tavolo base componibile \ modular base table

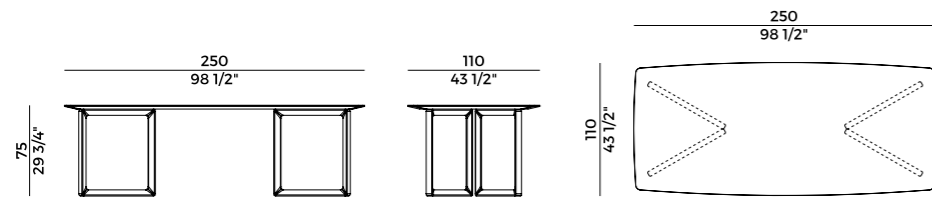

893/TR
 tavolo base componibile \ modular base table

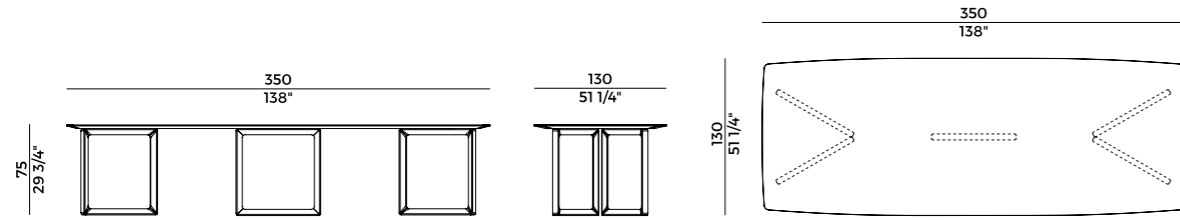

893/TR
 tavolo base componibile \ modular base table

OTAB

Design Gabriele e Oscar Buratti
 \ pag. 088

Tavolo tondo con piano circolare e base cilindrica centrale in frassino o noce Canaletto e dettaglio in ottone brunito.

Circular table with central cylindrical base in ash wood or Canaletto walnut and detail in bronzed brass.

Piano disponibile in due varianti:
 - Piano in frassino impiallacciato o noce Canaletto impiallacciato con bordi massellati.
 - Piano in marmo.

Top available in two versions:
 - Top in veneered ash wood or veneered Canaletto walnut and solid wood edges.
 - Marble top.

Accessorio abbinato: piatto centrale girevole lazy susan in frassino, marmo o noce Canaletto.

Matching accessory: lazy susan central rotating plate in solid ash wood, marble, or Canaletto walnut.

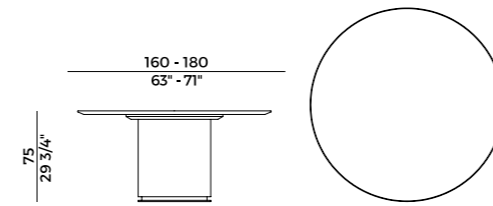

883/T
 tavolo \ table

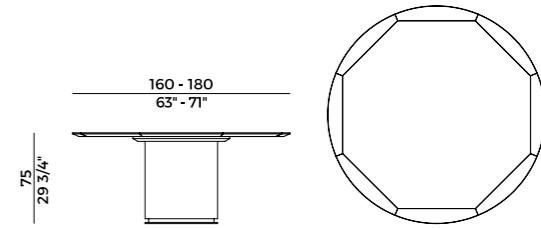

OTTA

Design Chiaramonte e Marin
 \ pag. 332

Collezione di sedute imbottite in poliuretano espanso ignifugo e tavolini. Sedia, poltrona e pouf con struttura in massello di faggio. Tavolini con struttura in massello di faggio e piano in marmo o faggio. Finiture e rivestimenti di collezione.

Collection of seats padded in fire retardant polyurethane foam padding and coffee tables. Chair, armchair and pouf with solid beech frame. Coffee tables with solid beech frame and marble or beech top. Materials and coverings as per collection.

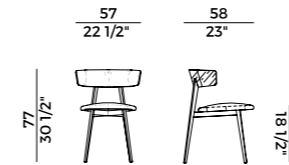

940
 sedia \ chair

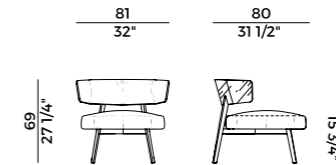

940/L
 poltrona \ armchair

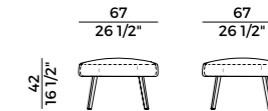

940/O
 pouf \ pouf

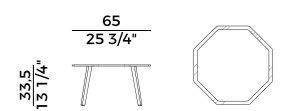

940/T
 tavolino \ coffee table

PIPE

Design Mario Ferrarini
 \ pag. 212

Famiglia di tavoli la cui base è caratterizzata idealmente da due cavalletti rovesciati in frassino e metallo con finitura in ottone brunito. Disponibile in due versioni:
 - Tavolo con piano rettangolare in frassino, grès porcellanato o marmo a basso spessore, arrotondato sugli angoli.
 - Tavolo allungabile con piano circolare interamente in frassino e con basamento rotondo in tubolare in ottone brunito. Allunga centrale. Finiture di collezione.

Tables' family whose base features, superlatively, two upturned trestles in ash wood and metal with bronzed brass finish. Available in two versions:
 - Table with rectangular top in ash wood, laminated porcelain, or marble with minimal thickness, rounded on the corners.
 - Extendable table with circular top entirely in ash wood with round tubular basement in bronzed brass. Central extension. Finishes as per collection.

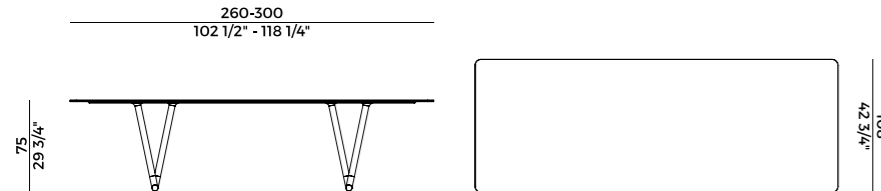

885/TR
 tavolo \ table

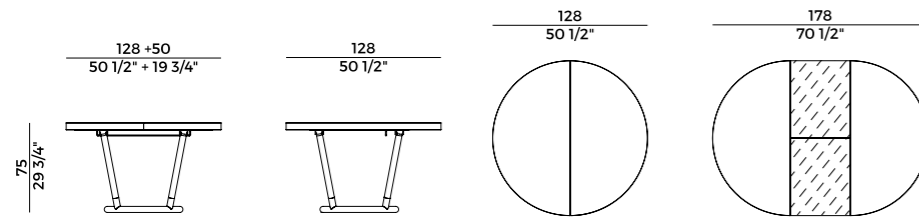

885/TC
 tavolo allungabile \ extendable table

360

PLISSÉ

Design Serena Confalonieri
 \ pag. 202

Sgabello con seduta imbottita in poliuretano espanso ignifugo e perimetro plissettato. Disponibile con o senza schienale. Gamba centrale girevole in metallo con regolazione a gas e base in metallo tonda. Finiture e rivestimenti di collezione.

Stool with seat padded in fire retardant polyurethane foam and pleated perimeter. Available with or without backrest. Central swivel metal leg with gas lift system and round metal base. Materials and coverings as per collection.

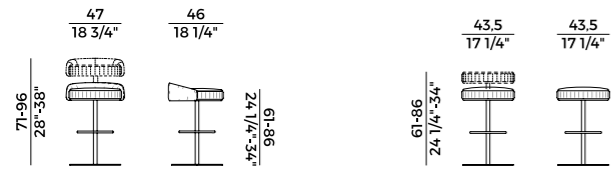

929/A-GAS
 sgabello up&down \ up&down stool

929/S-GAS
 sgabello up&down \ up&down stool

POCKET

Design Luis A. Arrivillaga
 \ pag. 120

Coppia di tavolini con struttura in metallo ottone brunito o antracite goffrato. Piano superiore laccato nero opaco. Tavolino sottostante, con contenitore aperto, disponibile in frassino. Finiture di collezione.

Pair of coffee tables with bronzed brass or embossed anthracite metal structure. Upper top in lacquered matt black. Small table below, with open container, available in ash wood. Finishes as per collection.

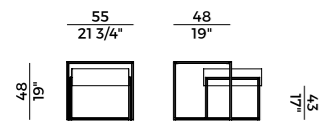

894/TB
 tavolino \ coffee table

PURPLE

Design Marco Viola Studio
 \ pag. 188

Divano componibile sfoderabile e poltrona. Struttura interna in legno massello di faggio e multistrato di betulla e imbottitura in poliuretano espanso ignifugo. Rivestimenti di collezione.

Modular sofa with removable covers and armchair. Internal frame in solid beech wood and birch plywood and padded in fire retardant polyurethane foam. Coverings as per collection.

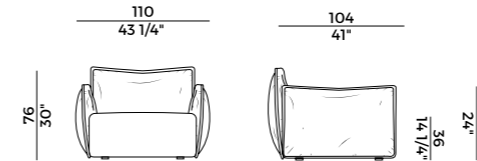

935/P
 poltrona \ armchair

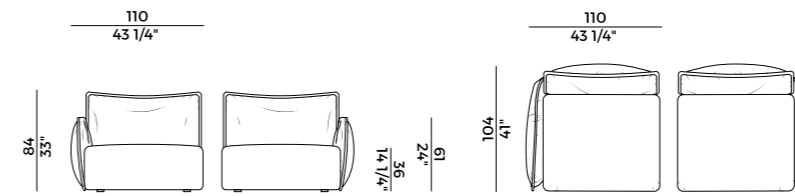

935/DT
 modulo laterale destro e sinistro \ right and left side unit

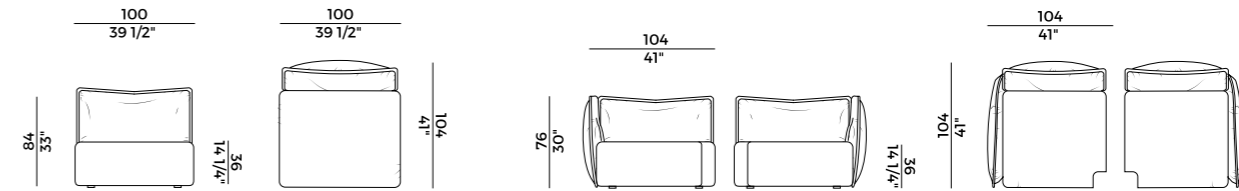

935/DM1
 modulo centrale \ central unit

935/DA-90°
 modulo angolare destro e sinistro \ right and left corner unit

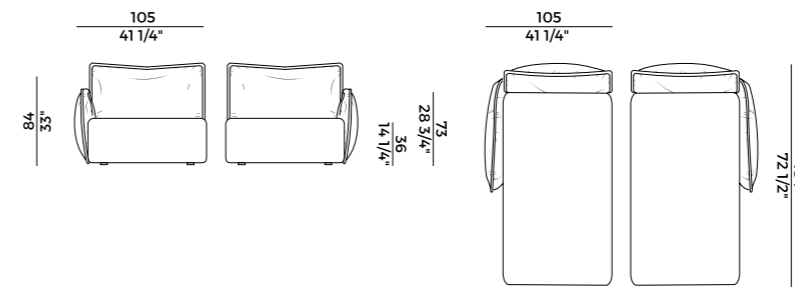

935/DCL
 modulo chaise longue destro e sinistro \ right and left chaise longue unit

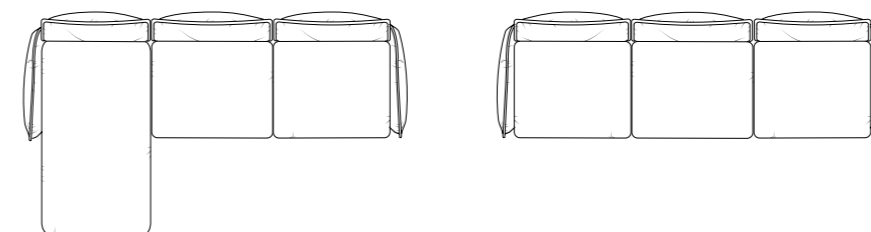

935/D
 divano componibile \ modular sofa

361

RONDÒ

Design Mauro Lipparini
 \ pag. 194

Tavolini in massello di rovere disponibili in due altezze. Disponibili con cuscino di seduta imbottito in poliuretano espanso ignifugo. Finiture e rivestimenti di collezione.

Coffee tables in solid oak wood available in two heights. Available with seat's cushion padded in fire retardant polyurethane foam. Materials and coverings as per collection.



827/TB
 tavolino \ coffee table

827/TM
 tavolino \ coffee table



827/T
 cuscino accessorio \ seat pad

ROPU

Design Chiara Andreotti
 \ pag. 176

Collezione di tavolini e pouf con struttura in metallo verniciato antracite goffrato e cornice con intreccio in cordino di cuoio o in cordino "Gassa" testa di moro. La collezione è così composta:

- Tavolino con top rettangolare in vetro retro verniciato nero temperato, grès porcellanato, HPL o marmo.
- Tavolino con top circolare in vetro retro verniciato nero temperato, grès porcellanato, HPL o marmo.
- Pouf rettangolare con cuscino sfoderabile imbottito in poliuretano espanso ignifugo.

Ropu è disponibile anche nella versione outdoor.

Collection of coffee tables and poufs with structure in embossed anthracite painted metal and frame woven in hide rope or "Gassa" rope, in dark brown finish. The collection is composed as follows:

- Coffee table with rectangular top in black back-painted tempered glass, laminated porcelain, HPL or marble.
- Coffee table with circular top in black back-painted tempered glass, laminated porcelain, HPL or marble.
- Rectangular pouf with removable cushion padded in fire retardant polyurethane foam.

Ropu is also available in the outdoor version.

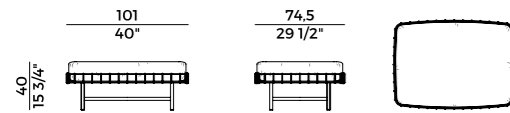

888/CQR-IN
 pouf \ pouf

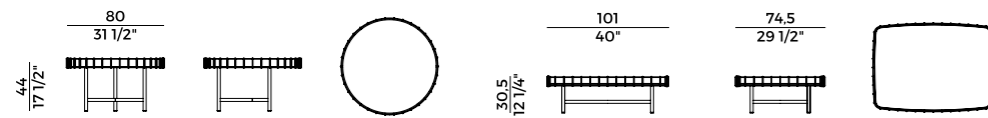

888/TBC
 tavolino \ coffee table

888/TBR
 tavolino \ coffee table

SCHEGGIA

Design Mario Ferrarini
 \ pag. 116

Poltrona con struttura in massello di noce Canaletto rastremata ai bordi. Disponibile con seduta imbottita in poliuretano espanso ignifugo o intrecciata a mano in cordino "Gassa" testa di moro. Finiture e rivestimenti di collezione.

Armchair with frame in solid Canaletto walnut tapered at the edges. Available with seat padded in fire retardant polyurethane foam or hand-woven in dark brown "Gassa" rope. Materials and coverings as per collection.

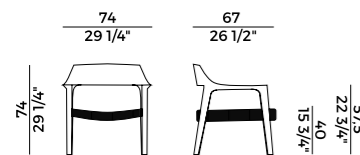

906/PLR
 poltrona seduta intrecciata \ woven seat armchair

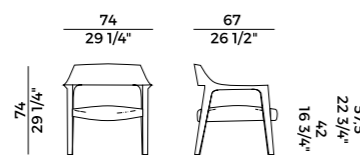

906/PLI
 poltrona seduta imbottita \ upholstered seat armchair

SEN

Design Chiara Andreotti
 \ pag. 284

Collezione di mobili contenitori, madia e credenza in frassino. Cornice in legno massello di frassino. Due ante scorrevoli in vetro temperato bronzo o trasparente a cui sono applicate griglie in frassino. Base con piedino in frassino e dettagli in metallo verniciato Aval. Credenza con tre ripiani. Madia con spalla centrale che suddivide in due lo spazio interno.

Collection of storage units, sideboard, and cabinet in ash wood. Frame in solid ash wood. Two sliding doors in tempered transparent or bronzed glass with attached grilles in ash wood. Base with foot in ash wood and details in Aval painted metal. Sideboard with 3 shelves. Cabinet with central shoulder that divides the internal space in two.

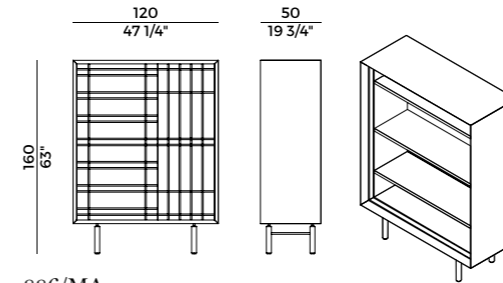

886/MA
 credenza \ cabinet

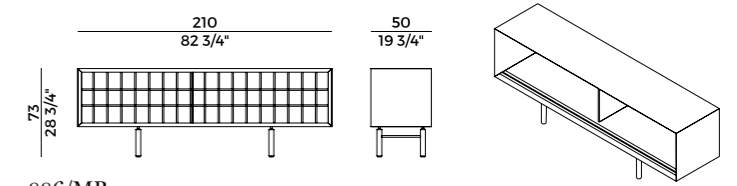

886/MB
 madia \ sideboard

SLICE

Design Marco Piva
 \ pag. 328

Famiglia di sedute imbottite in poliuretano espanso ignifugo con gambe in massello di faggio. Poltroncina disponibile con braccioli imbottiti. La sedia e poltroncina con braccioli in legno sono impilabili. Finiture e rivestimenti di collezione.

Family of seats padded in fire retardant polyurethane foam and solid beech legs. Small armchair available with upholstered armrests. The chair and the small armchair with wooden armrests are stackable. Materials and coverings as per collection.

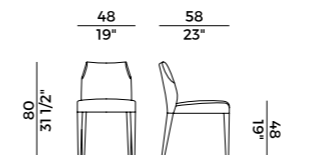

772
 sedia impilabile \ stackable chair

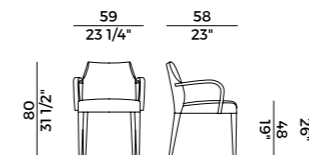

772/PW
 poltroncina impilabile \ stackable small armchair

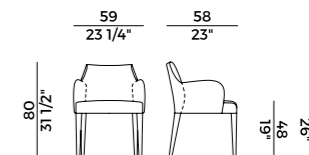

772/PI
 poltroncina \ small armchair

SPRING

Design Bernhardt & Vella
 \ pag. 290

Collezione di sedute in massello di faggio e tavolini con struttura in massello di frassino. Divano, Bergère e pouf imbottiti in poliuretano espanso ignifugo. Disponibili anche in versione bimaterica. Tavolini con piano in frassino, marmo o vetro temperato retro verniciato. Finiture e rivestimenti di collezione.

Collection of solid beech wood seating and coffee tables with solid ash wood frame. Sofa, wing chair and pouf padded in fire retardant polyurethane foam. Available also in the bi-material version. Coffee tables with ash wood, marble, or tempered back-painted glass top. Materials and coverings as per collection.

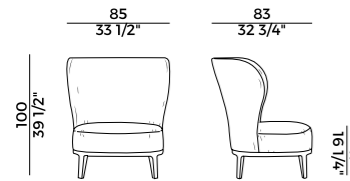

841/P
 bergère \ wing chair

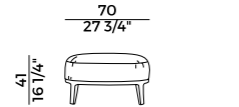

841/S
 pouf \ pouf

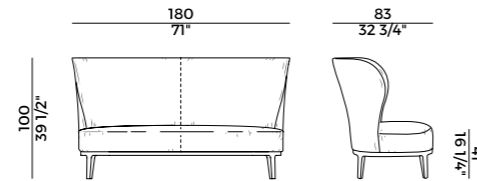

841/D
 divano \ sofa

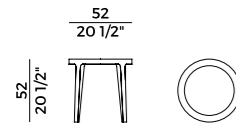

841/TBC
 tavolino \ coffee table

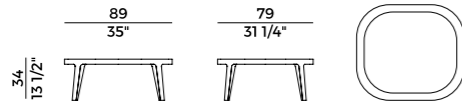

841/TBQ
 tavolino \ coffee table

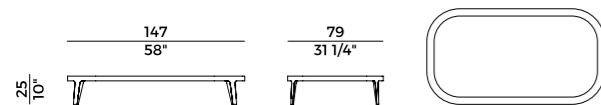

841/TBR
 tavolino \ coffee table

STAY

Design StorageMilano
 \ pag. 142

Poltrona con seduta e schienale imbottiti in poliuretano espanso ignifugo. Struttura in tubolare di metallo verniciato antracite goffrato o ottone brunito. Rivestimenti di collezione.

Armchair with seat and backrest padded in fire retardant polyurethane foam. Structure in metal rod, in bronzed brass or anthracite embossed painted metal finishes. Coverings as per collection.

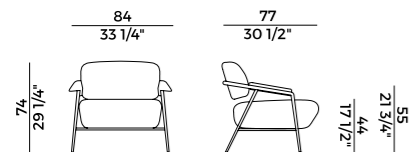

909/PL
 poltrona \ armchair

STILLA

Design Serena Confalonieri
 \ pag. 310

Specchio a parete con cornice ed elemento di fissaggio rivestiti in pelle. Tubolari di raccordo in metallo finitura ottone brunito.

Wall mirror with frame and attachment element covered in leather. Tubular joints in bronzed brass finish metal.

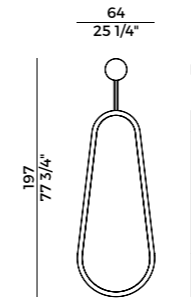

890/S
 specchio a parete \ wall mirror

TALE

Design StorageMilano
 \ pag. 252

Specchio autoportante con cornice frontale in metallo verniciato antracite goffrato. Cornice interna, dettaglio e fascia inferiore in ottone brunito o antracite goffrato.

Freestanding mirror with frontal frame in anthracite embossed painted metal. Internal frame, detail and lower band in bronzed brass or embossed anthracite.

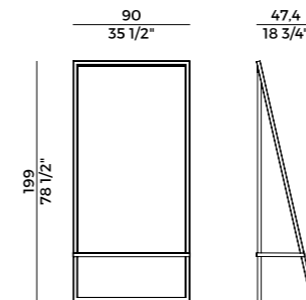

891/S
 specchio autoportante \ freestanding mirror

TERRAZZO

Design Nicola Bonriposi
 \ pag. 080

Scrivitoio con leggera struttura in acciaio tubolare verniciato a polveri antracite goffrato, con dettagli piedini e dettagli cilindrici di fissaggio del piano in finitura ottone brunito. Piano e spalla in lamiera, con inserto soft pad in poliuretano espanso, rivestiti in cuoietto e rifiniti da cuciture perimetrali a vista.

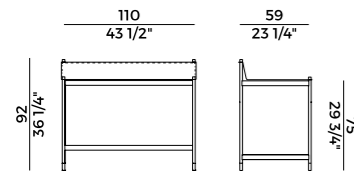

898/SCR
scrivitoio \ writing desk

Writing desk with structure in powder coated tubular steel in embossed anthracite, with feet and cylindrical fixing details in bronzed brass finish. Top and shoulder in thin plate, with soft polyurethane foam pad insert, covered with hide-leather, and refined with visible perimeter seams.

TORSO

Design Gianluigi Landoni
 \ pag. 170

Collezione di arredi così composta:
 - Tavolo con struttura in massello di frassino o noce Canaletto e dettagli in ottone brunito. Disponibile circolare con struttura singola e rettangolare con doppia struttura. Piano in frassino, noce Canaletto e vetro temperato bronzo.
 - Sgabello con seduta imbottita in poliuretano espanso ignifugo. Gamba centrale girevole e base in metallo tonda o quadrata, con sistema di regolazione a gas.

Furniture collection composed as follows:
 - Table with structure in solid ash wood or Canaletto walnut and details in bronzed brass. Available in the circular version with single structure and in the rectangular version with double structure. Top in ash wood, Canaletto walnut or tempered bronzed glass.
 - Stool with seat padded in fire retardant polyurethane foam. Central swivel leg and round or square metal base, with gas lift system.

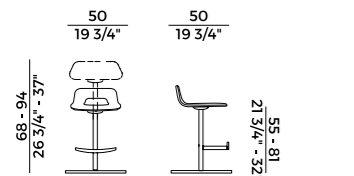

837/AI-GAS
sgabello up&down \ up&down stool

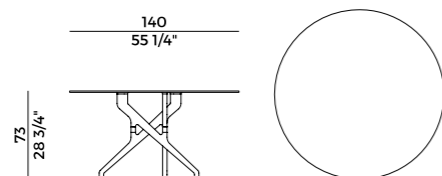

837/T3
tavolo \ table

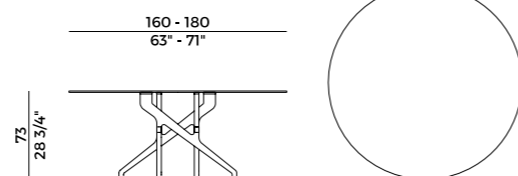

837/T4
tavolo \ table

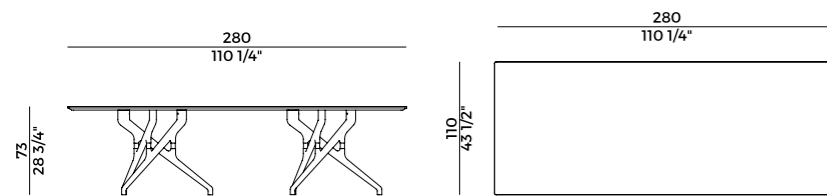

837/TR
tavolo \ table

TRACK

Design Favaretto & Partners
 \ pag. 240

Sedia lounge in frassino o noce Canaletto con schienale e seduta imbottiti in poliuretano espanso ignifugo. Finiture e rivestimenti di collezione.

Lounge chair with ash wood or Canaletto walnut frame and seat and backrest padded in fire retardant polyurethane foam. Materials and coverings as per collection.

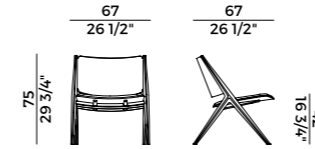

919/L
sedia lounge \ lounge chair

TRAY

Design Marco Viola Studio
 \ pag. 256

Famiglia di tavolini a tre altezze con struttura in metallo verniciato antracite goffrato o ottone brunito. Piano circolare, quadrato o rettangolare in marmo e vetro temperato retro verniciato. Cornice in frassino. Finiture di collezione.

Family of coffee tables with three different heights with structure in embossed anthracite painted metal or bronzed brass. Circular, square, or rectangular top in marble and tempered back painted glass. Ash wood frame. Finishes as per collection.

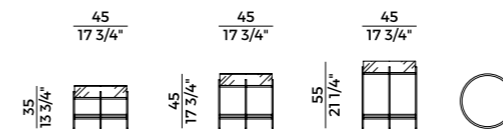

872/T/C
tavolino \ coffee table

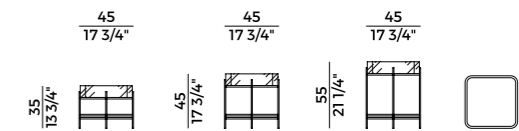

872/T/Q
tavolino \ coffee table

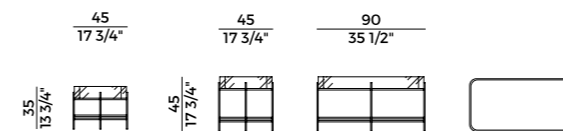

872/T/R
tavolino \ coffee table

VELIS

Design Mario Ferrarini
 \ pag. 036

Collezione di sedute imbottite in poliuretano espanso ignifugo e struttura in massello di frassino o in noce Canaletto così composta:

- Sedie e poltroncine imbottite in poliuretano espanso ignifugo con schienale in due diverse altezze. Struttura in massello di frassino o noce Canaletto.
 - Poltroncina pozzetto con seduta e schienale imbottiti in poliuretano espanso ignifugo. Struttura in massello di frassino o noce Canaletto.
 - Poltroncina pozzetto girevole con meccanismo di ritorno con seduta e schienale imbottiti in poliuretano espanso ignifugo. Dettagli seduta in massello di frassino o noce Canaletto e base girevole a quattro razze in metallo verniciato nero gofrato.
 - Poltroncina pozzetto con schienale intrecciato con seduta imbottita in poliuretano espanso ignifugo. Struttura in massello di frassino o noce Canaletto.
 - Divano e poltrona con schienale alto con seduta e schienale imbottiti in poliuretano espanso ignifugo. Struttura in massello di frassino o noce Canaletto.
 - Divano e poltrona con schienale basso con seduta e schienale imbottiti in poliuretano espanso ignifugo. Struttura in massello di frassino o noce Canaletto.
 - Poltrona girevole con meccanismo di ritorno con seduta e schienale imbottiti in poliuretano espanso ignifugo. Dettagli seduta in massello di frassino o noce Canaletto.
 - Sgabello singolo in due altezze differenti, sgabello doppio e sgabello circolare senza schienale. Seduta e schienale imbottiti in poliuretano espanso ignifugo. Dettagli seduta in massello di frassino o noce Canaletto.
 - Sgabello con seduta pozzetto con gamba centrale girevole e base in metallo tonda o quadrata, con sistema di regolazione a gas.
 - Panche imbottite in poliuretano espanso ignifugo in differenti dimensioni con o senza tavolino. Struttura in massello di frassino o noce Canaletto. Finiture e rivestimenti di collezione.
- Collezione disponibile anche in versione bimaterica.

- Collection of seats padded in fire retardant polyurethane foam and structure in solid ash wood or Canaletto walnut composed as follows:
- Chairs and small armchairs padded in fire retardant polyurethane foam and backrest in two different heights. Structure in solid ash wood or Canaletto walnut.
 - Tub chair with seat and backrest padded in fire retardant polyurethane foam. Structure in ash wood or Canaletto walnut.
 - Tub chair with four-star swivel base, with return mechanism, in embossed black painted metal. Seat and backrest padded in fire retardant polyurethane foam. Seat details in solid ash wood or Canaletto walnut.
 - Tub chair with handwoven backrest, seat and backrest padded in fire retardant polyurethane foam and structure in solid ash wood or Canaletto walnut.
 - Sofa and armchair with seat and high backrest padded in fire retardant polyurethane foam. Structure in solid ash wood or Canaletto walnut.
 - Sofa and armchair with seat and low backrest padded in fire retardant polyurethane foam. Structure in solid ash wood or Canaletto walnut.
 - Swivel armchair with return mechanism with seat and backrest padded in fire retardant polyurethane foam. Seat details in solid ash wood or Canaletto walnut.
 - Single stool in two different heights, double stool, and circular stool without backrest. Seat and backrest padded in fire retardant polyurethane foam. Seat details in solid ash wood or Canaletto walnut.
 - Stool with central swivel leg and round or square metal base, with gas lift system.
 - Benches padded in fire retardant polyurethane foam, in different sizes, with or without table. Structure in solid ash wood or Canaletto walnut. Finishes and covering as per collection.
- Collection available also in the bi-material version.

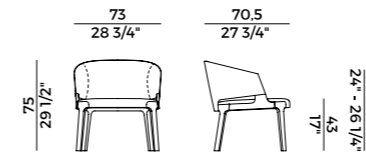

942/PLA
 poltrona \ armchair

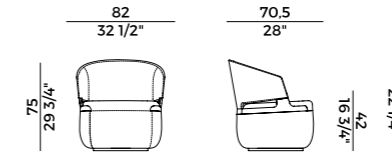

942/PLAG
 poltrona girevole \ swivel armchair

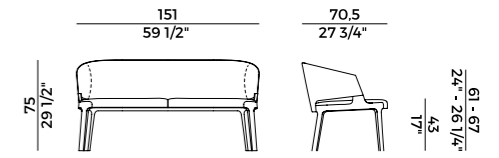

942/DA
 divano \ sofa

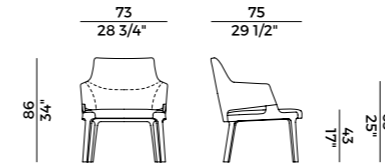

942/PLB
 poltrona \ armchair

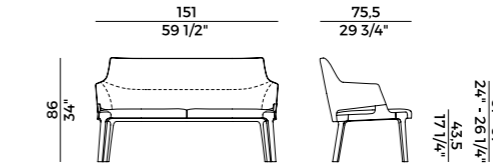

942/DB
 divano \ sofa

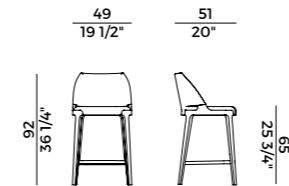

942/AS
 sgabello basso \ counterstool

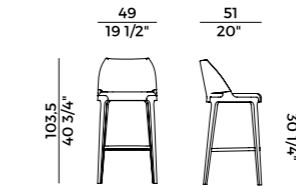

942/A
 sgabello alto \ barstool

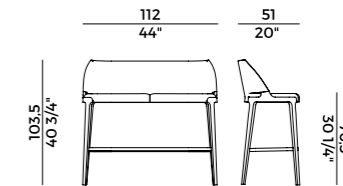

942/A2
 sgabello doppio \ double stool

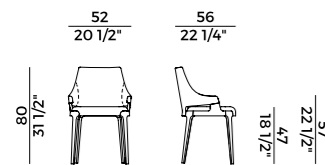

942
 sedia \ chair

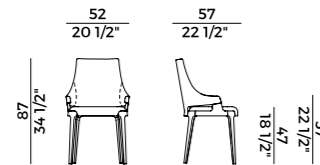

942/7
 sedia schienale alto \ high backrest chair

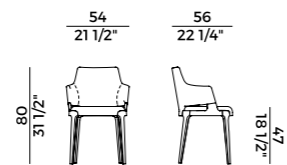

942/PB
 poltroncina \ small armchair

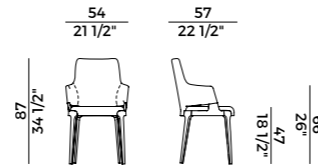

942/PB7
 poltroncina schienale alto \ high backrest small armchair

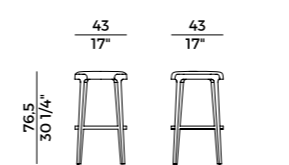

942/AC
 sgabello \ stool

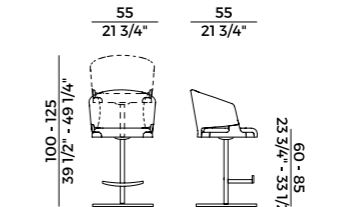

942/APA-GAS
 sgabello up&down \ up&down stool

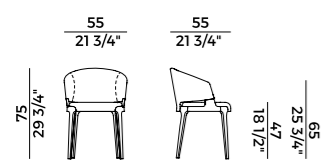

942/PA
 poltroncina pozzetto \ tub chair

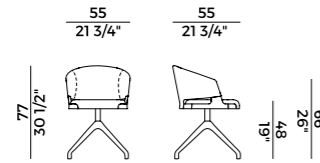

942/PAG
 poltroncina pozzetto girevole \ swivel tub chair

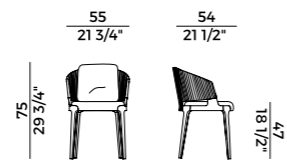

942/PAR
 poltroncina pozzetto schienale intrecciato \ woven backrest tub chair

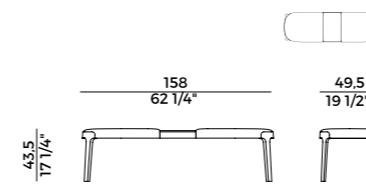

942/O1
 panca \ bench

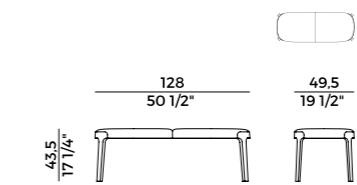

942/O2
 panca \ bench

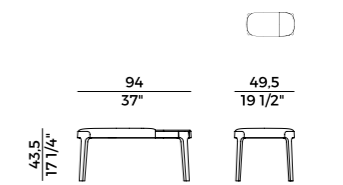

942/O3
 panca \ bench

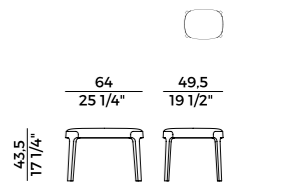

942/O4
 panca \ bench

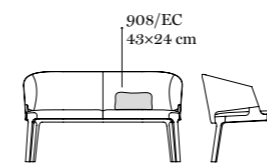

942/EC
 cuscino \ cushion

VENUS

Design Alexander Lorenz
 \ pag. 320

Poltroncina, poltrona e pouf con struttura in massello di faggio, imbottite in poliuretano espanso ignifugo. Finiture e rivestimenti di collezione.

Small armchair, armchair and pouf with solid beech structure, padded in fire retardant polyurethane foam. Materials and coverings as per collection.

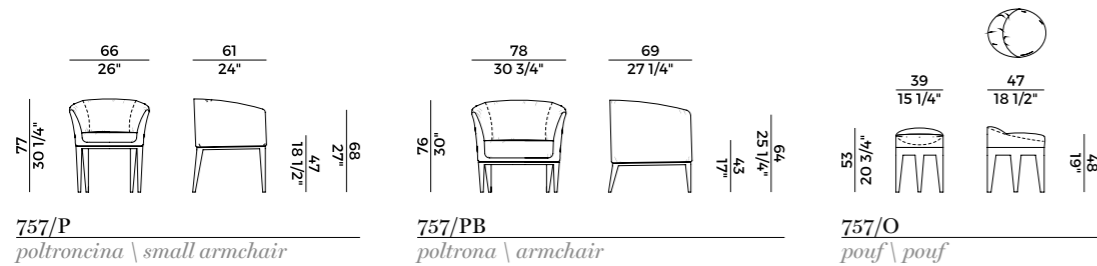

757/P
 poltroncina \ small armchair

757/PB
 poltrona \ armchair

757/O
 pouf \ pouf

VIGO

Design David Lopez Quincoces
 \ pag. 206

Lounge con struttura in tubolare di metallo verniciato ottone brunito con schienale e seduta in cuoio autoportante. Cuscino poggiatesta incluso. Finiture e rivestimenti di collezione.

Lounge chair with tubular metal frame painted in bronzed brass finish with self-supporting backrest and seat in saddle leather. Headrest included. Materials and coverings as per collection.

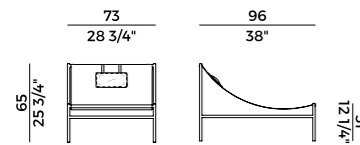

881/L
 lounge \ lounge chair

WOOD_Y

Design Chiara Andreatti
 \ pag. 278

Famiglia composta da scrittoio, consolle autoportante e consolle a parete. Base e piano in massello di frassino. Tondini e dettagli delle teste delle viti in metallo con finitura ottone brunito. Opzionale per lo scrittoio un cassetto sotto piano nella stessa finitura del mobile.

Family composed of writing desk, freestanding console, and wall console. Base and top in solid ash wood. Rods and details of the screws' heads in metal in bronzed brass finish. Optional for the writing desk, a drawer under the top in the same finish as the furniture item.

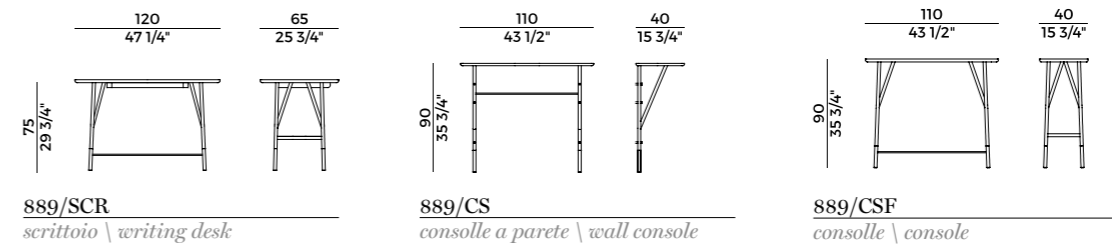

889/SCR
 scrittoio \ writing desk

889/CS
 consolle a parete \ wall console

889/CSF
 consolle \ console

YOISHO

Design Bernhardt & Vella
 \ pag. 270

Poltrona con imbottitura in poliuretano espanso ignifugo. Dettaglio alla base della seduta in legno finitura ottone brunito. Gambe in massello di frassino.

Armchair padded in fire retardant polyurethane foam. Detail at the base of the seat in wood with bronzed brass finish. Solid ash wood legs.

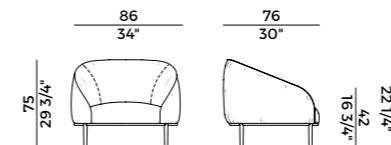

904/PL
 poltrona \ armchair

CUSCINI DECORATIVI \ DECORATIVE PILLOWS

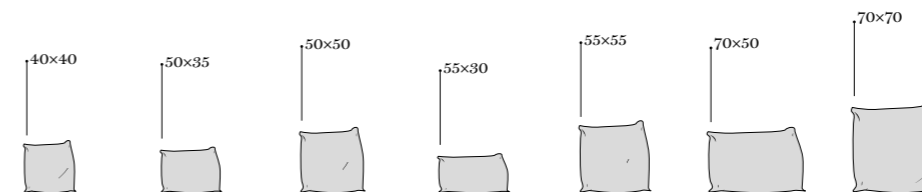

cuscini decorativi \ decorative pillows

Fin-
ishes

05.



articolo ignifugo
flame retardant

FAGGIO TINTO
STAINED BEECH



BV
Anilina Beige
Beige Aniline

UD
Biscotto
Biscuit

TM
Moka
Moka



TZ
Grigio Plumbeo
Dark Grey

TT
Wengé
Wengé

15
Carbone
Carbon

FRASSINO TINTO
STAINED ASH

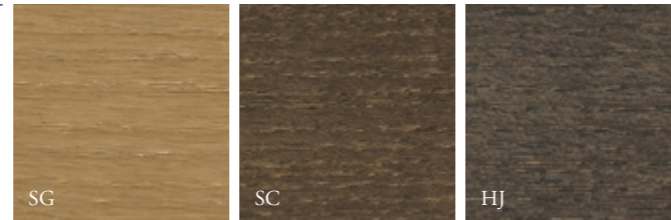

SG
Anilina Beige
Beige Aniline

SC
Biscotto
Biscuit

HJ
Moka
Moka



HK
Grigio Plumbeo
Dark Grey

HL
Wengé
Wengé

HP
Carbone
Carbon

ROVERE TINTO
STAINED OAK

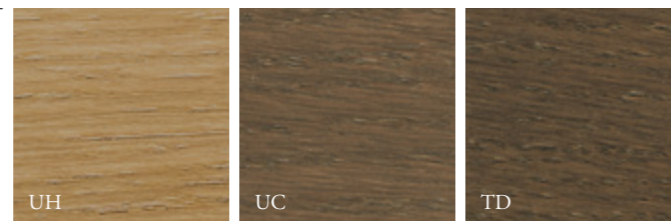

UH
Anilina Beige
Beige Aniline

UC
Biscotto
Biscuit

TD
Moka
Moka

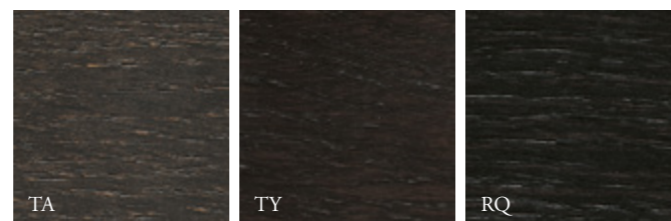

TA
Grigio Plumbeo
Dark Grey

TY
Wengé
Wengé

RQ
Carbone
Carbon

LACCATI OPACHI
MATT LACQUERED



13
Bianco
White

HB
Rubino
Ruby Red

08
Nero
Black

NOCE CANALETTO
CANALETTO WALNUT

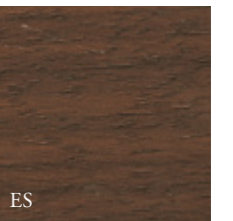

ES
Opaco
Matt

MOGANO
MAHOGANY

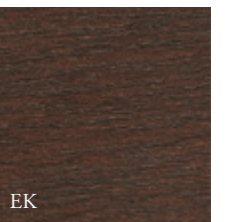

EK
Tinto Noce
Walnut Stained

METALLI VERNICIATI
LACQUERED METALS

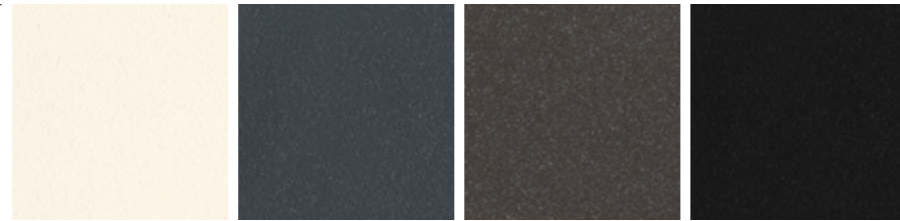

Bianco Goffrato
White Embossed

Antracite Goffrato
Anthracite Embossed

Aval Goffrato
Aval Embossed

Nero Goffrato
Black Embossed

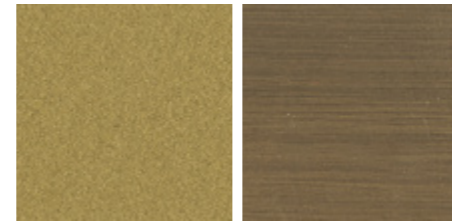

Oro
Gold

Ottone Brunito
Bronzed Brass

METALLI SPECIALI
SPECIAL METALS

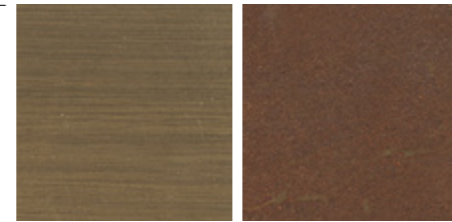

Ottone Brunito
Bronzed Brass

Corten

INOX
INOX



Satinato
Satin

METALLI CROMATI
CHROME METALS

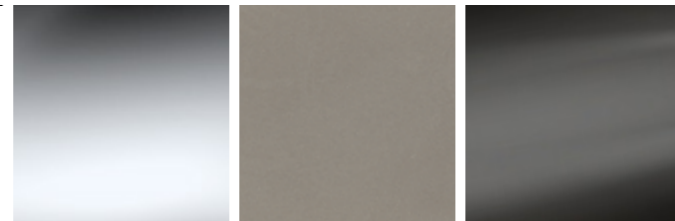

Cromato
Chrome

Cromo Satinato
Satin Chrome

Cromo Nero
Black Chrome

MARMI
MARBLES

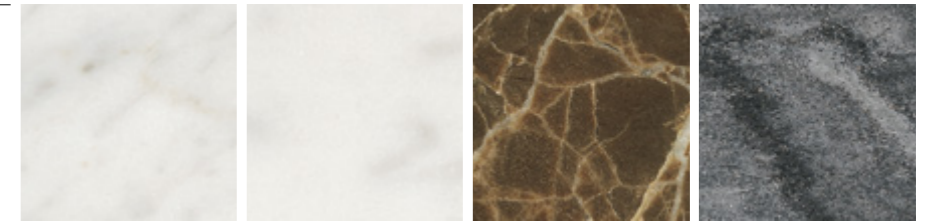

Bianco Carrara opaco
Matt white Carrara

Bianco Carrara lucido
Glossy white Carrara

Dark Emperador

Iron Silver

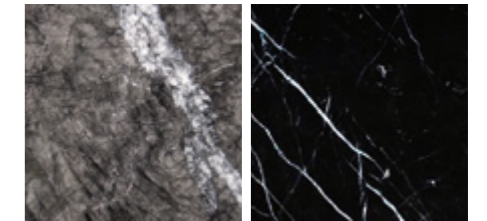

Grigio Carnico

Nero Marquinia

GRÈS PORCELLANATO
LAMINATED PORCELAIN

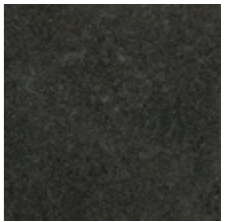

Ossido Nero
Black Ossido

QUARZO RESINATO
RESINATED QUARTZ

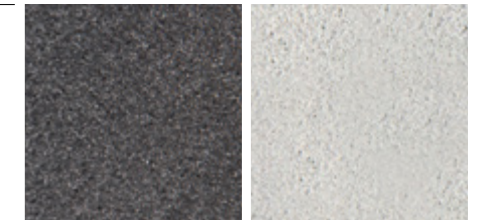

Antracite
Anthracite

Light Grey

VETRO TEMPERATO
TEMPERED GLASS

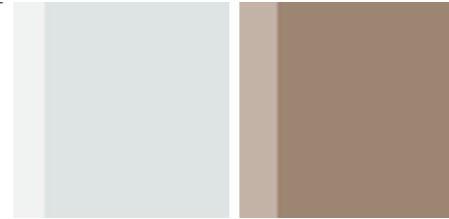

Float Trasparente
Transparent Float

Bronzato
Bronzed

VETRO TEMPERATO RETRO VERNICIATO
TEMPERED BACK-PAINTED GLASS



Nero
Black

CERAMICA
CERAMIC

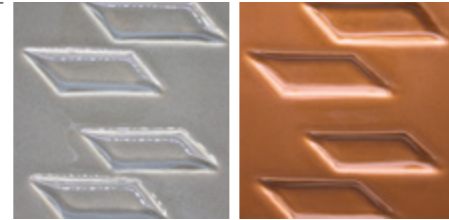

Grigio Sabbia
Sand Grey

Pesca
Peach

HPL
HPL



Antracite
Anthracite

CORDINI
ROPES



A6C
Cuoio
Hide Leather

CORDA NAUTICA
NAUTICAL ROPE



F9B
Canapa
Hemp

CORDINI GASSA
GASSA ROPES



F7E
Testa di Moro
Dark Brown

ADO - Cat.1

39% VI, 25% PES, 17% LI, 14% CO, 4% AC, 1% AF
MARTINDALE - 20.000 cicli/rubs

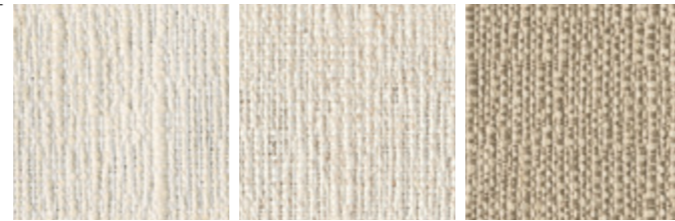

C5A Bianco C5B Panna C5C Beige

Care

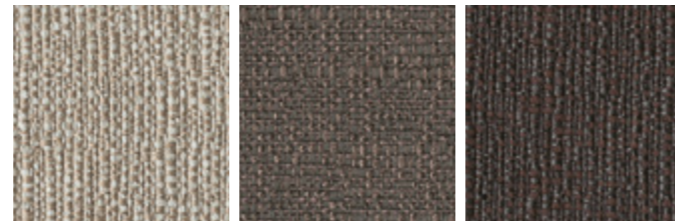

C5G Grigio chiaro C5D Nocciola C5E Marrone

AIDA - Cat.1 **NEW**

68% PL, 32% PP
MARTINDALE - > 135.000 cicli/rubs

Fire tests

IIM-UNI 9175
Classe 1-UNI 9177
EN 1021 Part 1/2
DIN 4102-B1
NF D-60 013-A18
CAL TB 117:2013
IMO MED-FTP 307 Part 8
Önorm B 3825

Note \ Notes

IMO-MED
Sound absorbent
Proposition 65

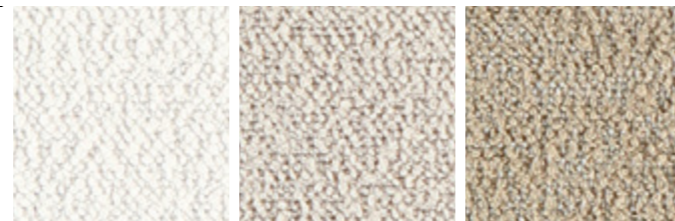

A2D Bianco A2E Beige A2F Sabbia

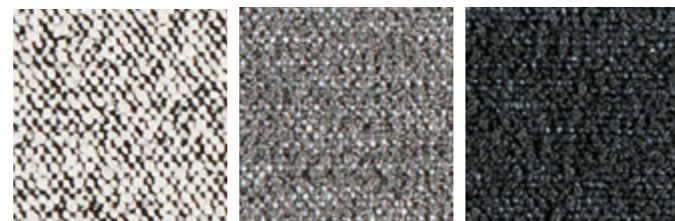

A2G Pepe A2H Grigio A2I Antracite

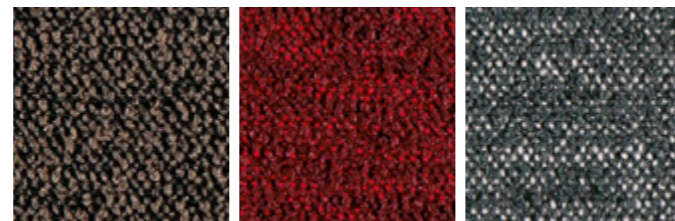

A2J Tronco A2K Rubino A2L Petrolio

Care



ARES - Cat.1

77% PL, 17% CO, 6% PC
MARTINDALE - 50.000 cicli/rubs



C7A Bianco C7B Ghiaccio C7C Oliva

Care

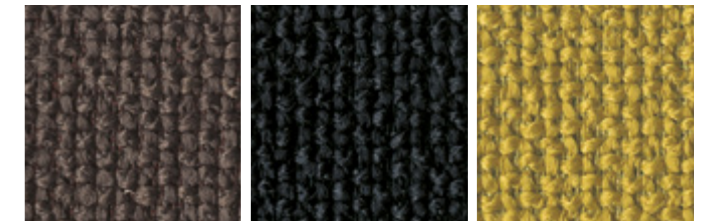
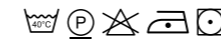

C7D Marrone C7E Nero C7F Senape

ARTE - Cat.1 **NEW**

68% PC, 16% PL, 16% CO
MARTINDALE - 25.000 cicli/rubs

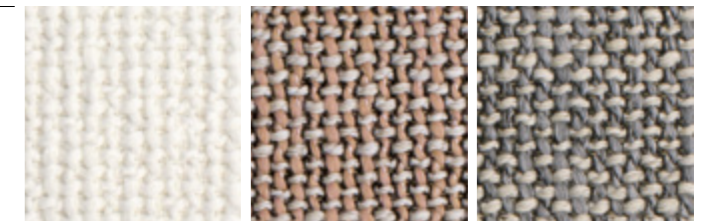

A1D Bianco A1E Rosa A1F Grigio chiaro

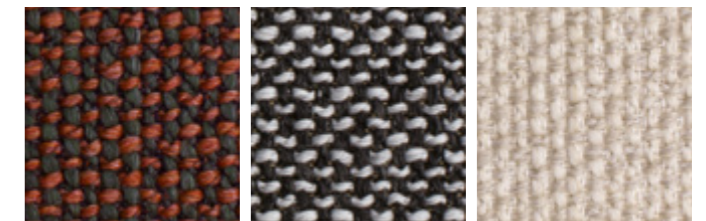

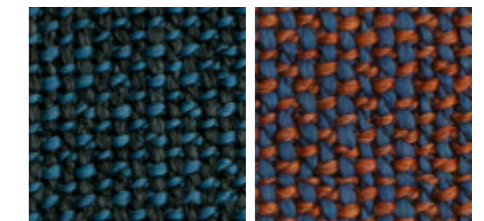

A1G Verde mattone A1H Pepe A1J Beige

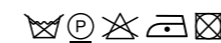

A1K Blu oltremare A1L Blu arancio

Care



BADIA - Cat.2 **NEW** 

47% PC, 26% CO, 9% LI, 9%PL, 9%VI
MARTINDALE - 30.000 cicli/rubs

Fire tests

BS 5852 Cigarette
BS 5852 Match

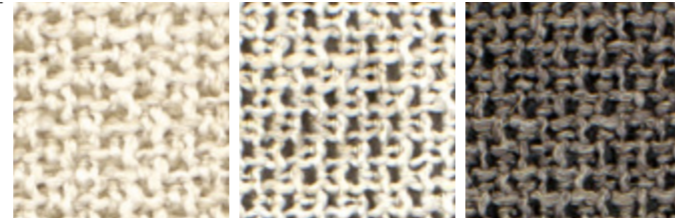

A5E
Panna

A5F
Pepe

A5G
Tronco

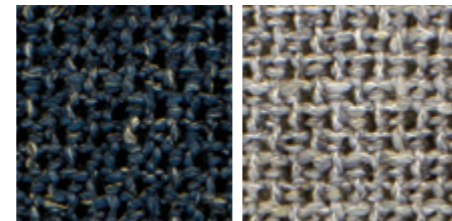

A5H
Blu oltremare

A5I
Grigio

Care



BARRIQUE - Cat.2 **NEW** 

33% CO, 15% VI, 12% LI, 20% PA, 20%PL
MARTINDALE - 100.000 cicli/rubs

Fire tests

BS 5852 Cigarette
BS 5852 Match

CAL TB 117:2013

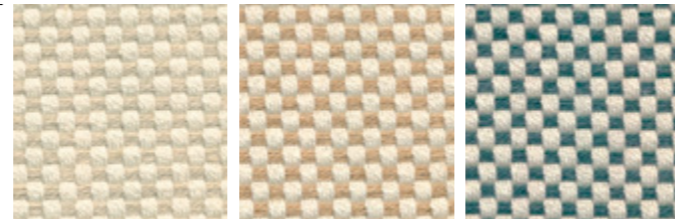

A7D
Panna

A7E
Beige

A7F
Petrolio



A7G
Sabbia

A7H
Grigio

A7I
Terracotta

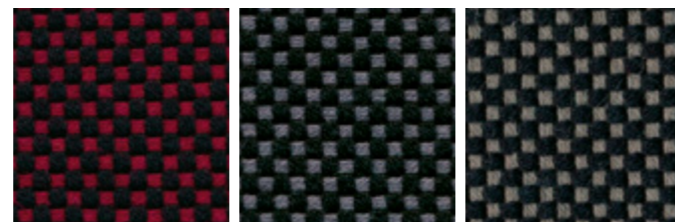

A7J
Rubino

A7K
Antracite

A7L
Grigio scuro

Care



BLISS - Cat.2

67% VI, 33% LI
MARTINDALE - > 20.000 cicli/rubs

Care



H1X
Bianco

H1Z
Beige

H1Y
Panna

H1W
Nocciola

BOSS - Cat.2

58% CO, 37% VI, 5% PL
MARTINDALE - 25.000 cicli/rubs



C7J
Panna

C7N
Bianco

C7L
Tortora

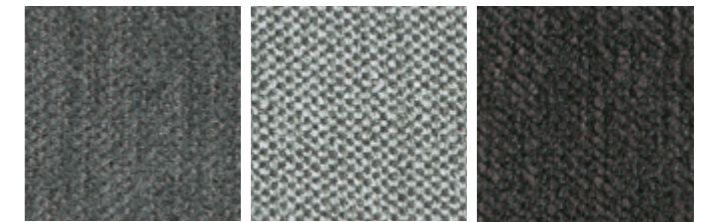

C7I
Grigio

C7K
Celeste

C7H
Antracite

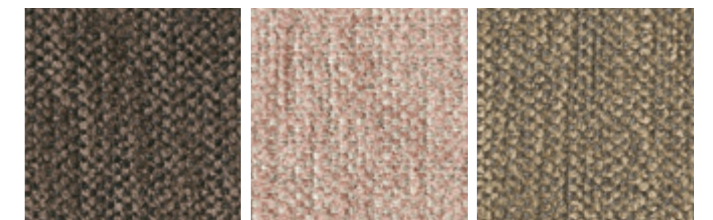

C7M
Oliva

C7G
Rosa

C7P
Grano

Care



BRERA - Cat.2 (Velluto \ Velvet) **NEW** 

100% CO
MARTINDALE - 40.000 cicli/rubs

Fire tests

BS 5852 Cigarette
BS 5852 Match
CAL TB 117:2013

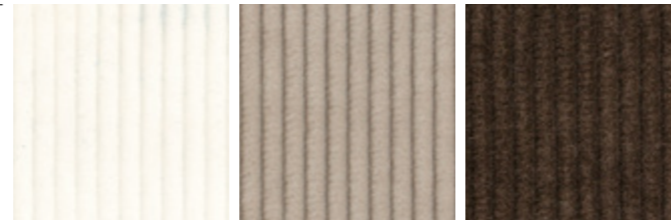

A4D Bianco A4E Beige A4F Tronco

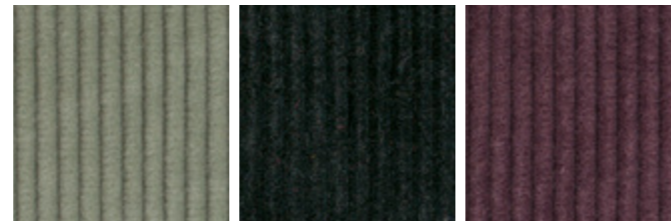

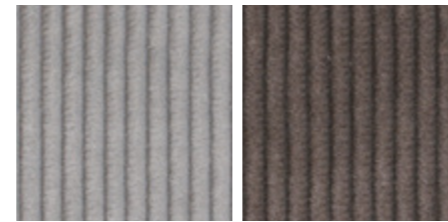

A4G Salvia A4H Antracite A4I Lilla

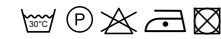

A4J Grigio A4K Tortora scuro

Care



BRIDGE - Cat.2 (Velluto \ Velvet) **NEW** 

100% Trevira® CS
MARTINDALE - 100.000 cicli/rubs

Fire tests

UNI 9175 1IM
UNI 9177 Classe 1
EN 1021-2
BS 5852 Crib 5
DIN 4102 - B1
NF92.503 - M1

Note \ Notes

Sound absorbent



A3D Bianco A3E Panna A3F Grigio



A3G Antracite A3H Salvia A3I Mattone

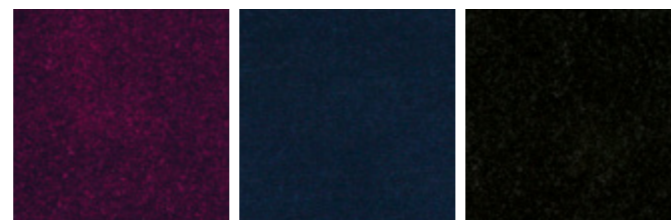

A3J Prugna A3K Blu oltremare A3L Nero

Care



CALIPSO - Cat.3 **NEW** 

35% CO, 25% PC, 18% PL, 13% VI, 9% WO
MARTINDALE - 40.000 cicli/rubs

Fire tests

BS 5852 Cigarette
BS 5852 Match
CAL TB 117:2013
EN 1021-1/2

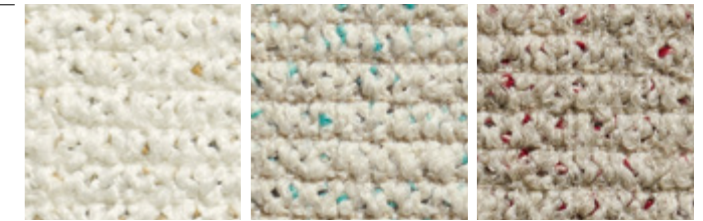

A8A Panna A8B Sabbia A8C Tortora

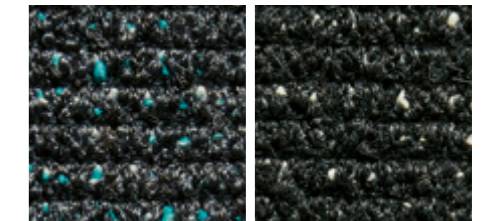

A8D Antracite A8E Nero

Care



CALLA - Cat.3 **NEW** 

5% CO, 25% VI, 13% LI, 15% WO, 25% PL, 15% PC, 2% PA
MARTINDALE - 45.000 cicli/rubs

Fire tests

BS 5852 Cigarette
BS 5852 Match
CAL TB 117:2013



A8L Panna A8M Sabbia A8N Smeraldo

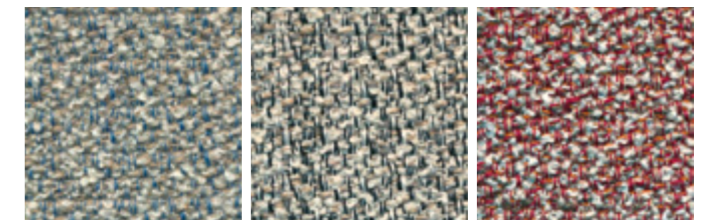

A8P Celeste A8Q Pepe A8R Rubino

Care



CELINE - Cat.3 

59% VI, 25% LI, 7% PL, 7% CO, 2% PC
MARTINDALE - 27.000 cicli/rubs

Fire tests

BS 5852 Cigarette
BS 5852 Match

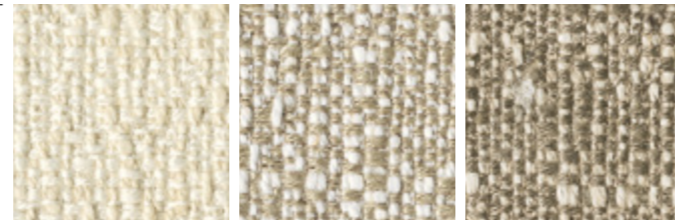

C6E Bianco C6F Ghiaccio C6D Beige

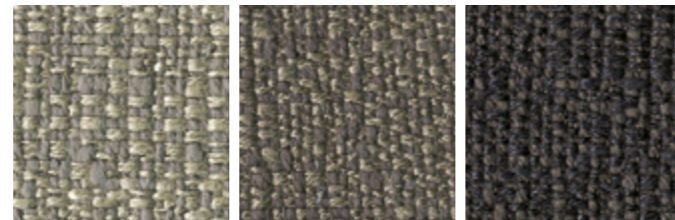

C6G Verde C6B Grigio C6C Nero

Care



CIELO - Cat.3 **NEW** 

47% CO, 18% LI, 35% VI
MARTINDALE - 50.000 cicli/rubs

Fire tests

BS 5852 Cigarette
BS 5852 Match
CAL TB 117:2013

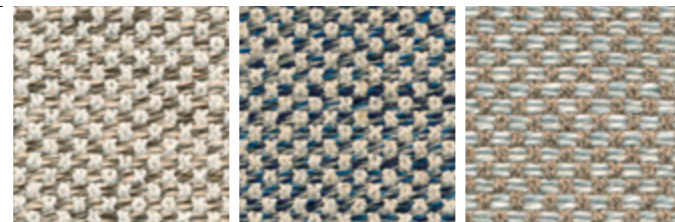

A6H Panna A6I Blu oltremare A6K Sabbia

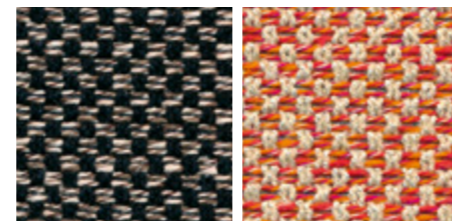

A6J Tronco A6L Mattone

Care

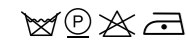

CORE - Cat.3

59% PL, 25% PC, 16% CO
MARTINDALE - 30.000 cicli/rubs

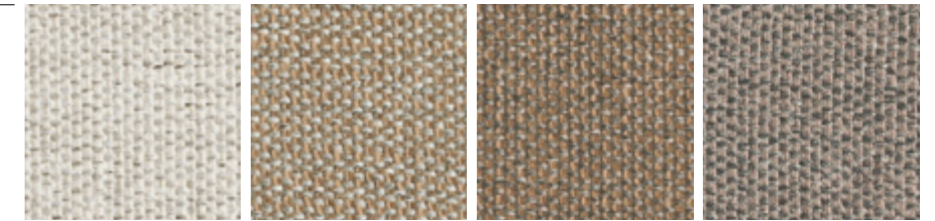

E1T Ghiaccio E1W Paglia E1Y Senape E1Z Marrone chiaro

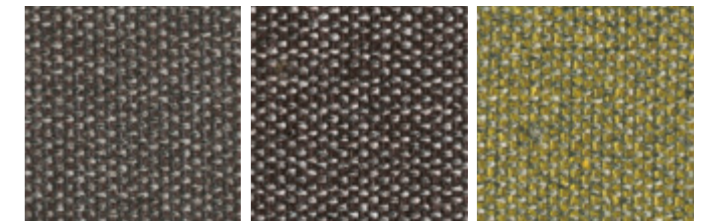

E1V Talpa E1X Testa di Moro E1U Fieno

Care



CORTINA - Cat.3 **NEW** 

100% PES FR
MARTINDALE - 50.000 cicli/rubs

Fire tests

BS 5852 Cigarette
BS 5852 Match
EN 1021-1/2
BS7176 Low hazard
CAL TB117:2013
NFPA 260
IMO Annex 1 Part 8
UNI 9175 1IM
NF D 60 013
DIN 4102 B2

Note \ Notes

STANDARD 100 by OEKO-TEX®
REACH approved chemicals and dyes
Biocide and PFCs free
Zero-waste production
Acoustic certificate: EN ISO 354

Care



A9A Bosco A9B Salvia A9C Blu oltremare

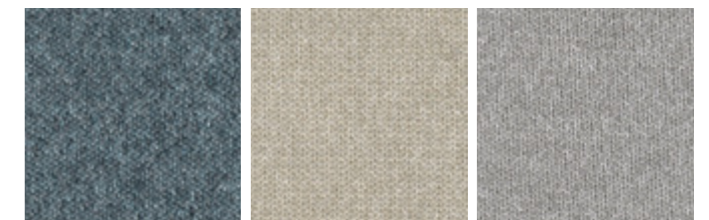

A9D Avio A9E Beige A9F Grigio

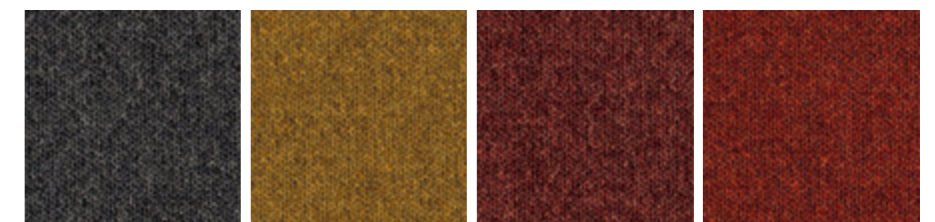

A9G Antracite A9H Senape A9I Terracotta A9J Mattone

DAFNE - Cat.4 **NEW** 

100% Trevira® CS
MARTINDALE - 170.000 cicli/rubs

Fire tests
Classe 1-IM
BS 5852 Cigarette
BS 5852 Match
CAL TB 117:2013



B2A Bianco B2B Panna B2C Sabbia B2D Mattone

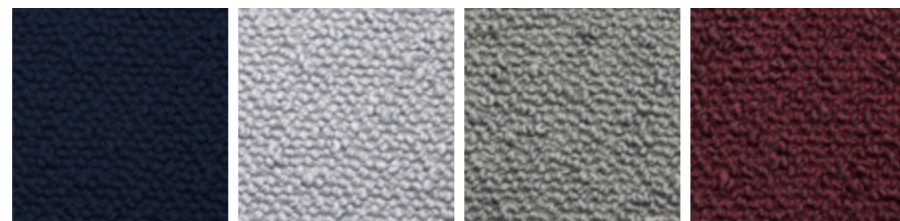

B2E Blu Oltremare B2F Grigio B2G Antracite B2H Rubino

Care 

DALÍ - Cat.4 **NEW** 

95% WV, 5% PA
MARTINDALE - 100.000 cicli/rubs

Fire tests
CAL TB 117:2013
EN 1021-1/2
UNI 9175 IIM
ÖNORM B1-Q1
IMO 2014/90/EU Marine Equipment Directive (MED)

Note \ Notes
Sound absorbent
Natural, renewable material
RAL-UZ 117 attachment 2+3
IWTO guidelines for wool sheep welfare
FR-Free
AB 2998 (US Export Standard)
REACH (EU Export Standard)
Naturally stain resistant

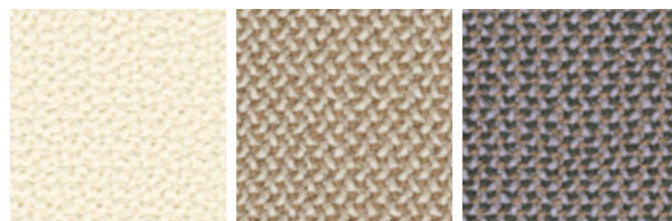

C6U Bianco C6V Sabbia C6Q Fango

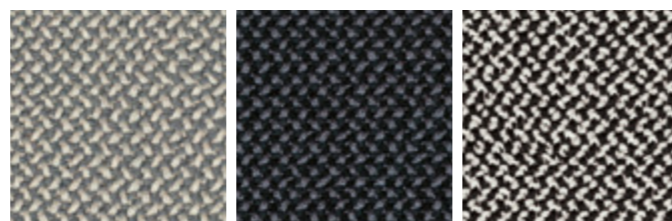

C6K Grigio C6L Antracite C6M Pepe



C6S Blue Navy C6I Grigio chiaro C6T Arancione

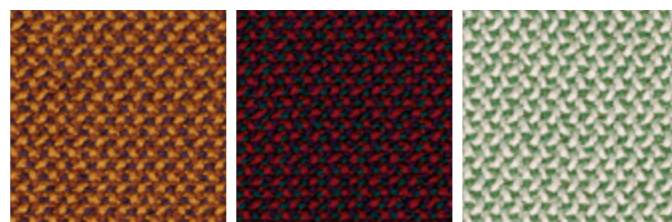

C6H Senape C6P Rubino C6N Salvia

Care 

DELTA - Cat.4 **NEW** 

50% CO, 33% VI, 17% LI
MARTINDALE - 35.000 cicli/rubs

Fire tests
BS 5852 Cigarette
BS 5852 Match
CAL TB 117:2013

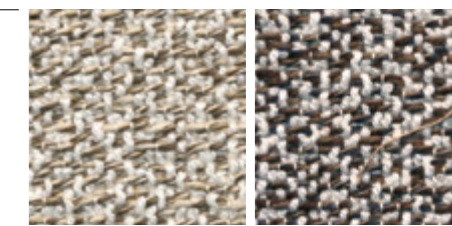

B1C Panna melange B1D Tronco melange

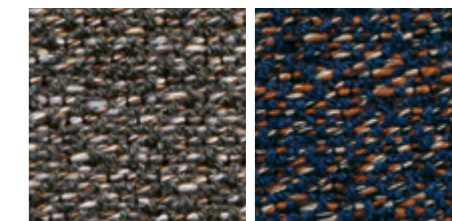

B1E Antracite melange B1F Blu mattone

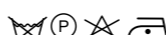
Care 

DOLINO - Cat.4 (Lino \ Linen)

100% LI
MARTINDALE - > 25.000 cicli/rubs

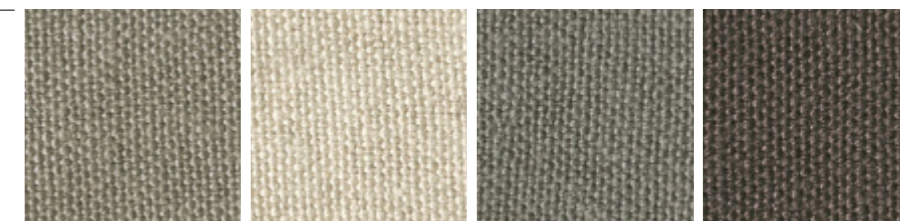

C8F Antracite C8D Sabbia C9U Tortora C8K Grigio

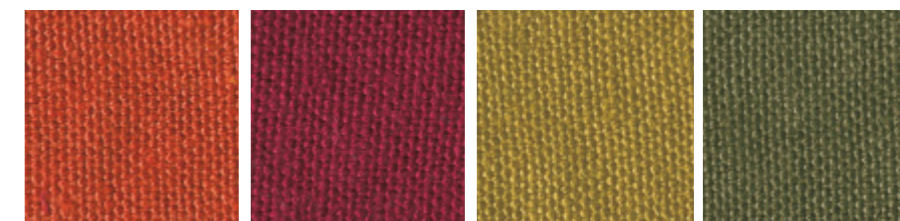

C9M Arancione C9G Rosso C8M Senape C8P Verde Oliva

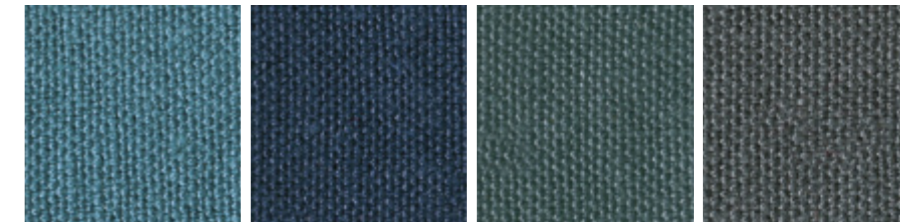

S2C Celeste C8Y Blu Scuro C8S Denim C9V Grigio Scuro

Care 

DORO - Cat.4 (Velluto \ Velvet)

100% CO
MARTINDALE - 100.000 cicli/rubs



H2H Crema H3C Sabbia H2J Nocciola H3E Ocra

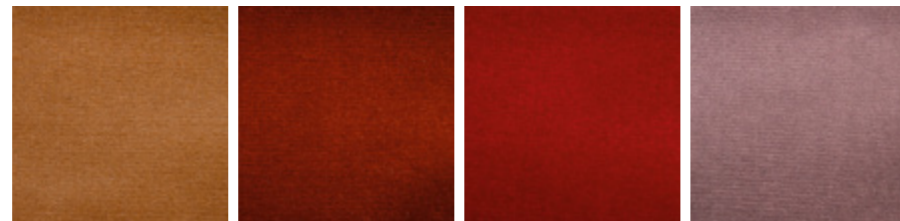

H3D Argilla H3F Ruggine H3G Rosso imperiale H3H Lilla

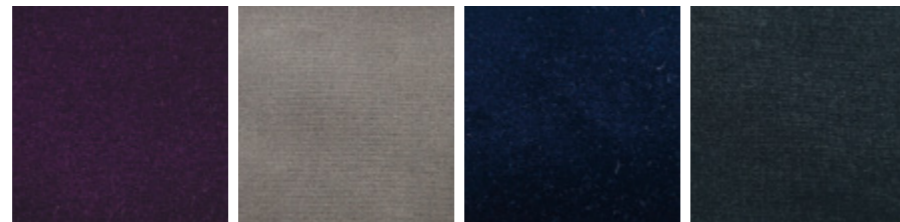

H3I Prugna H3J Grigio H2N Notte H2L Antracite

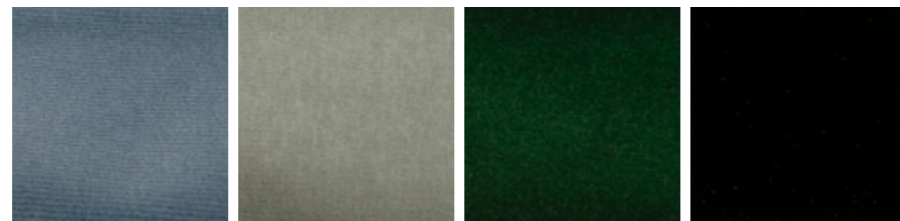

H3A Celeste H3L Salvia H3M Bosco H3B Nero

Care



FLAMINGO B - Cat.2 (Finta pelle \ Faux leather)

10% CO, 20% PES, 1% PU, 69% PVC
MARTINDALE - 100.000 cicli/rubs

Fire tests

UNI 9175 1IM

IMO-FTP

CAL TB 117:2013



Q1C Ecrú Q1D Beige Q1E Grigio scuro

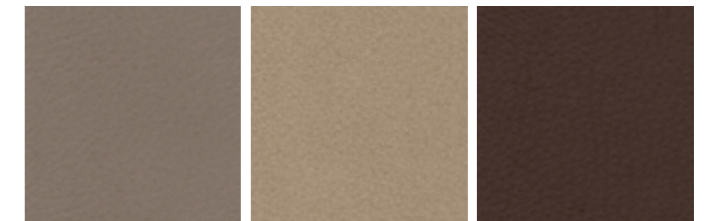

Q1A Tortora scuro Q1F Nocciola Q1G Mogano



Q1H Bordeaux Q1I Blu Notte Q1B Nero

Care



FALABELLA - Cat.3 (Finta pelle \ Faux leather)

63% PU, 29% CO, 8% PES
MARTINDALE - 150.000 cicli/rubs

Fire tests

UNI 9175 1IM

EN 1021-1/2

BS 5852 Crib 5

BS 5852 Match

IMO 2010 FTP CODE

CAL TB 117:2013

Note \ Notes

Waterproof

Resistance to mould and bacteria

Phthalates free

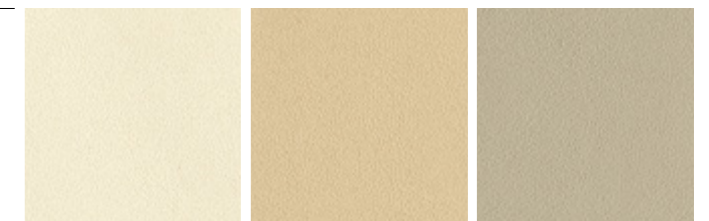

KN Panna KP Beige PM Tortora chiaro

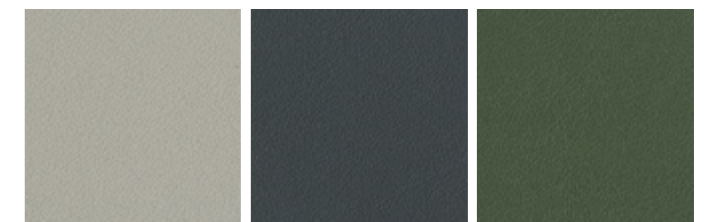

PF Grigio chiaro PG Antracite YA Verde oliva



KV Bronzo KU Marrone Testa di Moro

Care



GEO - Cat.A (Pelle \ Leather) 

Bovino europeo \ European bovine
 Fiore corretto \ Corrected grain
 Spessore \ Thickness - 0,9 - 1,1 mm

Fire tests

EN 1021-1/2
 BS 5852 Cigarette
 BS 5852 Match
 IMO MED FTP8 A652
 CAL TB 117:2013

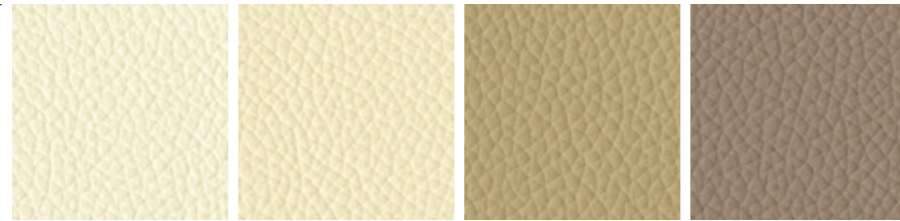

P2A Panna
 P1B Grano
 P1D Beige scuro
 P2D Tortora

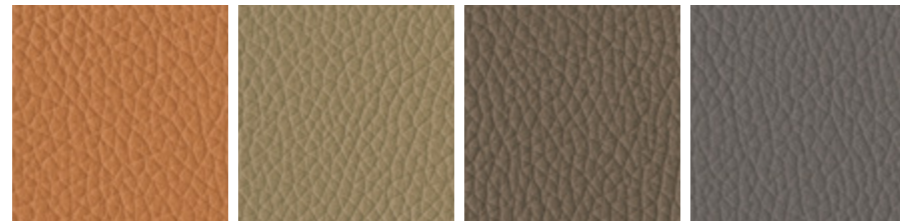

P2C Ruggine
 P1K Nocciola
 P1M Tronco
 P2G Grigio scuro



P1N Noce
 P2H Marrone Scuro
 P1T Terracotta
 P1V Rosso

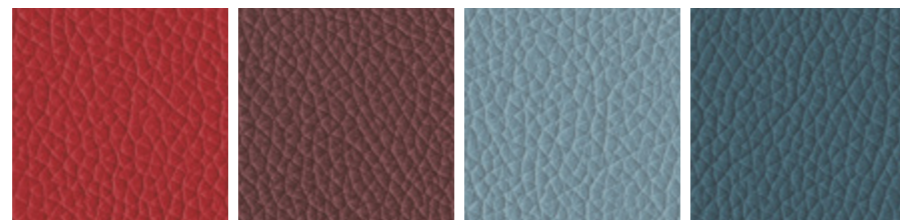

P1W Bordeaux
 P2N Melanzana
 P2Q Celeste
 P2S Blu cadetto



P2T Blu Prussia
 P3B Verde chiaro
 P3C Verde
 P2F Nero

GALEA - Cat.B (Pelle \ Leather) 

Bovino europeo \ European bovine
 Fiore corretto \ Corrected grain
 Spessore \ Thickness - 1,0 - 1,2 mm

Fire tests

EN 1021-1/2
 BS 5852 Cigarette
 BS 5852 Match
 IMO MED FTP8 A652
 CAL TB 117:2013



C4I Bianco
 C4Q Beige
 C4T Tortora chiaro
 C4U Tortora



C4P Zucca
 C4H Rosso scuro
 C4V Dattero
 C4K Castagna

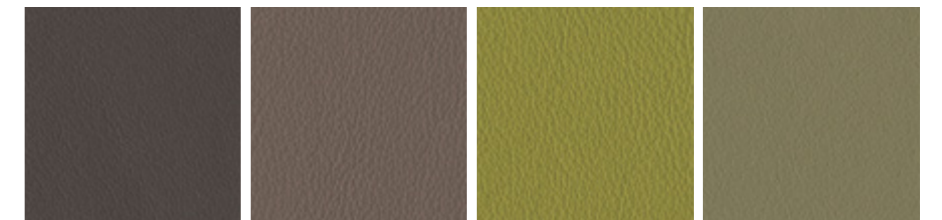

C4L Marrone scuro
 C4S Marmotta
 C4W Verde muschio
 C4N Verde mimetico

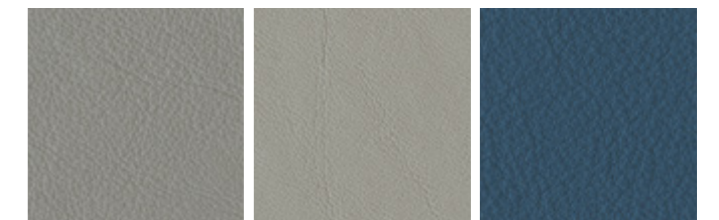

C4R Grigio
 C4J Grigio chiaro
 C4G Bluette

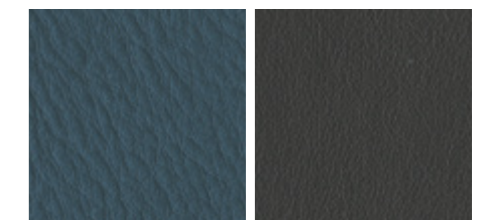

C4M Blu
 C4F Nero

NINA - Cat.B (Pelle \ Leather)

Bovino europeo \ European bovine
 Pieno fiore \ Full grain
 Spessore \ Thickness - 0,9 - 1,0 mm

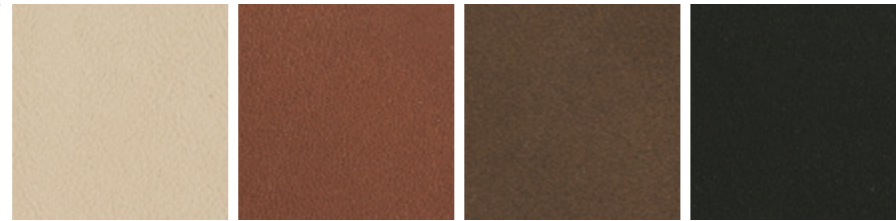

KK Naturale XZ Nocciola KL Marrone KJ Nero

NABUK - Cat.C (Pelle \ Leather)

Bovino europeo \ European bovine
 Nabuk idrorepellente \ Water-repellent Nabuk
 Spessore \ Thickness - 1,1 - 1,3 mm

Fire tests

EN 1021-1/2
 BS 5852 Cigarette
 BS 5852 Match
 IMO MED FTP8 A652
 CAL TB 117:2013

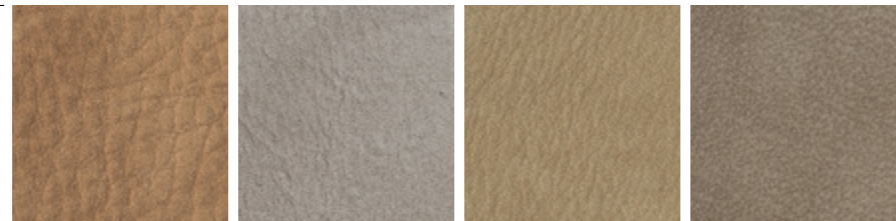

E2Q Nocciola E2T Tortora E2R Avena E2U Marmotta

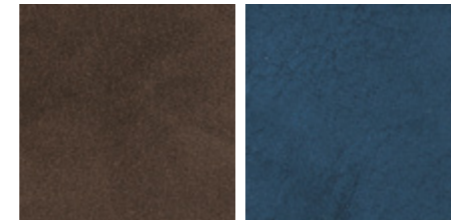

E2S Wengé E2V Blu

NATURE - Cat.C (Pelle \ Leather)

Bovino europeo \ European bovine
 Anilina pieno fiore \ Aniline full grain
 Spessore \ Thickness - 1,0 - 1,2 mm

Fire tests

EN 1021-1/2
 BS 5852 Cigarette
 BS 5852 Match
 CAL TB 117:2013
 NFPA 260/UFAC

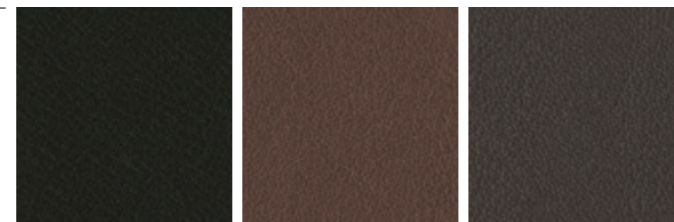

C9X Antracite C9Y Marrone C9Z Testa di Moro

CUOINETTO \ *HIDE LEATHER*

Bovino europeo \ European bovine
 Fiore liscio \ Smooth grain
 Spessore \ Thickness - 1,8 mm



K1F Sabbia K1B Fango 1S Grigio K1C Terracotta



BL Burgan K1D Marrone scuro BM Nero IZ Cognac

CUOIO \ *SADDLE LEATHER*

Bovino europeo \ European bovine
 Pieno fiore \ Full grain
 Spessore \ Thickness - 2,7 mm

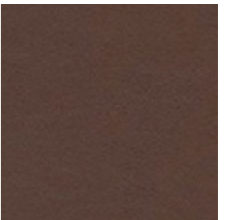

C6A Testa di Moro

POTOCOCCO
ITALY

© 2021 Potocco Spa
Via Indipendenza 4
33044 | Manzano | Udine | Italy
T. +39 0432 745111
info@potocco.it

Potocco USA
Hickory, NC 28602
United States of America
customerservice@potocco-usa.com

Potocco reserves the right to
introduce any changes to its own
models without prior notice.

© 2021 by Potocco Spa
All rights reserved



The mark of
responsible forestry
"Richiedi i nostri
prodotti certificati
FSC®"



www.potocco.it



Project Coordination
Potocco Corporate Image Team

Photos
Miro Zagnoli

Other photographs
Filippo Savoia \ p. 002-003
Simone Vrech \ p. 005
Matteo Baldan \ p. 006-011

Styling
Ilaria Baccocchi

Printed in Italy
Grafiche Filacorda
February 2021

Thanks to

Ames Design	Pietro Russo
Amini	Pulpo
Atelier Areti	RAW Milano
Astep ApS	Restart Milano
Bitossi Ceramiche	Salvatori
Bloc studios	Sara Ricciardi
Bosa Trade	Scandola Marmi
Catellani & Smith	Society Limonta
cc-tapis	Vano Alto
Corrado Corradi	Warli Tappeti contemporanei
Davide Giulio Aquini	Woody Zoody
FontanaArte	ZP Studio
Golran	
Gum Design	
i and i	
I Santi	
Ichendorf	
Interno Italiano	
Kanz Architetti	
Karpeta	
Kundalini	
Luceplan	
Masons	
MMairo - Marble & Design	
MM Lampadari	
Nemo Lighting	
Normann Copenhagen	
Oluce	
Paola Caravati Ceramics	

